

TURBINE PUMPS CP SERIES

CSF HYGIENIC TURBINE PUMP CP

Instructions for assembly, installation,
operation and maintenance



Colly FLOWTECH

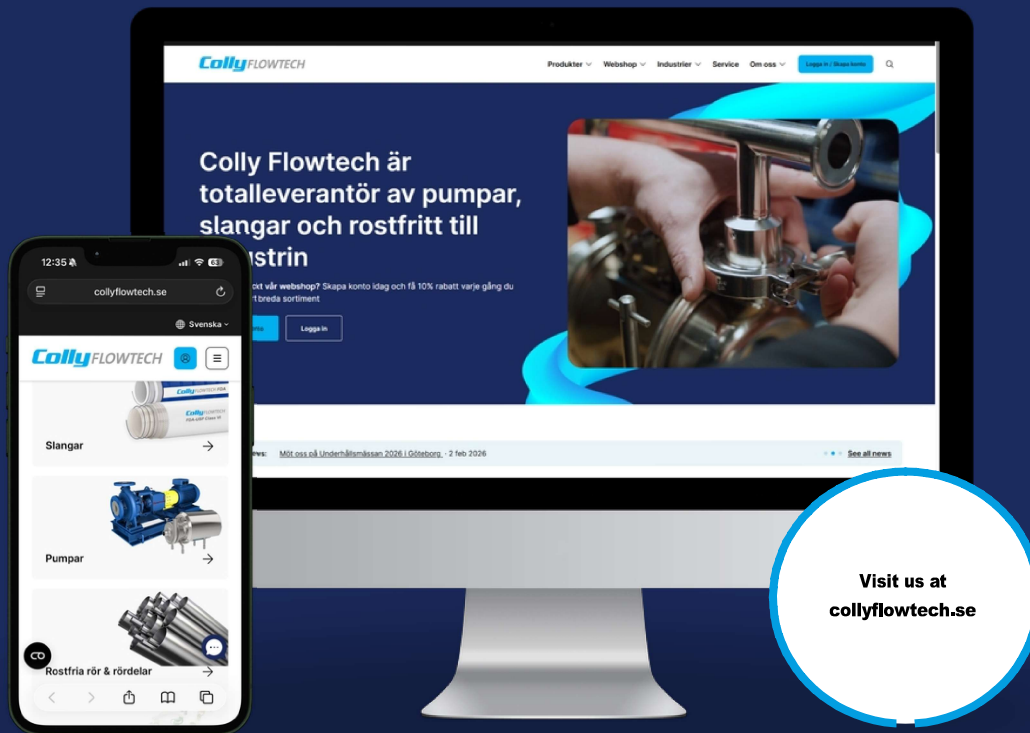

DO YOU HAVE ANY QUESTIONS OR NEED HELP?

Visit www.collyflowtech.se or contact us, and we'll put you in touch with the right specialist. We help you keep your operations running smoothly, reduce unplanned downtime and get the right spare parts on time.

HERE'S WHAT WE OFFER:

- On-site service at your premises or in our service workshops
- Pump servicing in fully equipped workshops
- Preventive maintenance and technical support for improved operational reliability
- Maintenance packages tailored to your operations
- Service reports and documentation
- Training for maintenance staff
- Expertise across multiple brands
- Spare parts and mechanical seals for multiple brands

FIND YOUR NEAREST SERVICE WORKSHOP AND REGISTER A SERVICE REQUEST. LEARN MORE HERE!



www.collyflowtech.se/pumpservice

Colly Flowtech AB

Sankt Eriksgatan 121A 113 43 Stockholm

info@collyflowtech.se

Tel +46 8 703 01 30

www.collyflowtech.se

PERIPHERAL IMPELLER PUMPS
Series CP

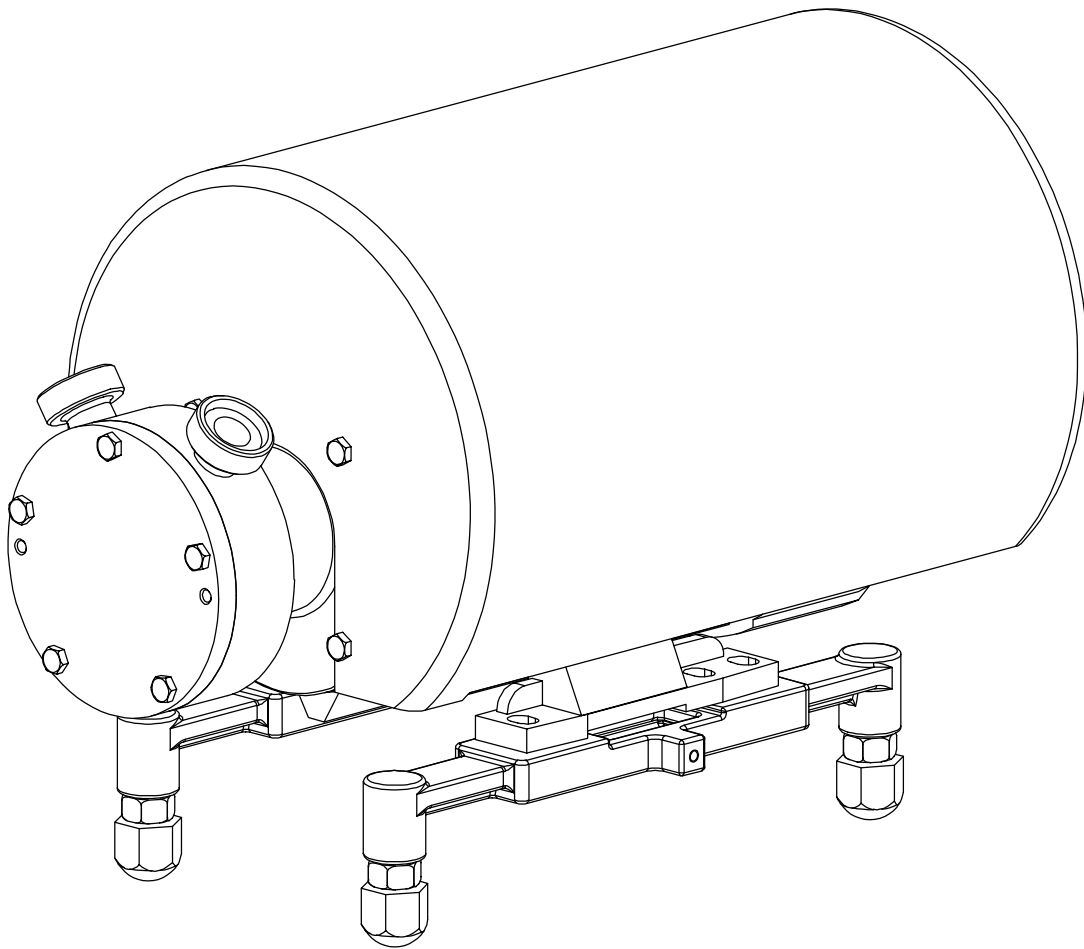

INSTRUCTIONS FOR ASSEMBLY, INSTALLATION,
OPERATION AND MAINTENANCE.

C.S.F. Inox S.p.A. reserves all rights concerning this manual and the object presented herein.

The receiving party shall recognize these rights and undertakes, in the absence of our explicit written authorization, not to use this manual for any purpose other than that for which it was created.

Any violations will be dealt with in accordance with the law.

All rights reserved.

© Copyright by

C.S.F. Inox S.p.A.

Strada per Bibbiano, 7

42027 Montecchio E. (RE) - ITALY EU

Ph +39.0522.869911 r.a. - Fx +39.0522.865454 / 866758 - italia@csf.it

www.csf.it

Self-printed.

Version: 03 Date: 23/01/2025

INDEX

FOREWORD	6
1.0 - SYMBOLS USED ON THE EQUIPMENT AND IN THE MANUAL	7
2.0 - SAFETY WARNINGS.....	8
2.1 - DANGER ZONES.....	9
2.2 - SAFEGUARDS.....	9
2.3 - OPERATORS AND RESPONSIBILITIES	10
3.0 - GUARANTEE	11
3.1 - CERTIFICATION AND EC MARKING.....	11
4.0 - GOODS TRANSPORTATION, RECEIVING AND TRANSFERRING.....	12
4.1 - TRANSPORT.....	12
4.2 - DELIVERY.....	12
4.3 - SITE PREPARATION.....	12
4.4 - TRANSFERRING	12
5.0 - RETURNS	13
6.0 - DESCRIPTION.....	14
6.1 - TECHNICAL DATA.....	14
6.2 - SOUND PRESSURE LEVEL	14
6.3 - WEIGHTS.....	15
7.0 - INTENDED USE	15
7.1 - INTENDED USE	15
7.2 - PROHIBITED USE.....	15
8.0 - INSTALLATION, HOOK-UP AND START-UP.....	16
8.1 - HANDLING AND LIFTING PRECAUTIONS	16
8.2 - TRANSPORT AND POSITIONING.....	16
8.3 - SUCTION AND INFLOW CONDITIONS	16
8.4 - PIPING	16
8.5 - ELECTRICAL CONNECTION	18
9.0 - OPERATION.....	19
9.1 - PRELIMINARY OPERATIONS BEFORE START-UP.....	19
9.2 - EXTENDED STOP.....	20
9.3 - CLEANING THE PUMP.....	20
10.0 - SPARE PARTS	21
10.1 - MAIN PARTS SUBJECT TO REPLACEMENT	21
10.2 - RECOMMENDED SUPPLY	21
11.0 - OPERATING MALFUNCTIONS.....	22
12.0 - MECHANICAL SEALS.....	23

13.0 - <i>DISASSEMBLY</i>	25
13.1 - <i>DISASSEMBLY OF CP PUMP "W" EXEC.</i>	25
13.2 - <i>DISASSEMBLY OF CP PUMP "Q" EXEC.</i>	27
14.0 - <i>PUMP ASSEMBLY</i>	28
14.1 - <i>ASSEMBLY OF PUMP "W" EXEC.</i>	28
14.2 - <i>ASSEMBLY OF PUMP "Q" EXEC.</i>	28
14.3 - <i>IMPELLER NUT DIMENSIONS</i>	28
15.0 - <i>CLEANING PROCEDURE</i>	29
15.1 - <i>EXTERNAL CLEANING</i>	29
15.2 - <i>CLEANING OF INTERNAL PARTS</i>	29
15.3 - <i>CLEANING OF FOOD-CONTACT PUMPS</i>	29
15.4 - <i>CIP WASHING PROCEDURE</i>	30
<i>DECLARATION OF DECONTAMINATION</i>	31
16.0 - <i>WASTE DISPOSAL AND DECOMMISSIONING</i>	32
16.1 - <i>PACKAGING MATERIALS</i>	32
16.2 - <i>WASTE RESULTING FROM MAINTENANCE OPERATIONS</i>	32
16.3 - <i>DISPOSAL OF THE PUMP</i>	32
<i>DECLARATION OF CONFORMITY</i>	33

FOREWORD

This instruction manual is designed to provide the user with all the information needed to perform all use and maintenance activities concerning the pump throughout its entire service life.

Read the instructions carefully and keep them for future consultation.

C.S.F. Inox S.p.A. reserves the right to make any changes to the documentation it deems necessary without being obliged to update publications that have already been issued.

This Manual contains confidential technical data owned exclusively by the Manufacturer/Constructor, consequently any copying of its contents and/or format (in their entirety or only partially) for any purposes other than those for which they were intended is prohibited without the Manufacturer's/Constructor's prior consent.

The official language chosen by the Manufacturer/Constructor is Italian. No liability shall be accepted for translations in other languages that do not match the original meaning.

All operators must read the instructions carefully and keep them for future reference. Refer to paragraph 2.2 Operators and responsibilities.

SIGNS AND DATA PLATES



The danger, warning and obligation signs illustrated in this manual are positioned on or near the equipment.

An exact description of the machine type, serial number and electrical voltage data will facilitate a rapid and effective response from the assistance service (when envisaged).

When requesting information, spare parts or assistance, always specify the pump type (2) and serial number (3) in order to ensure fast and efficient service: the complete code is given on the plate and in the purchase documents.

This manual refers exclusively to the pump supplied.







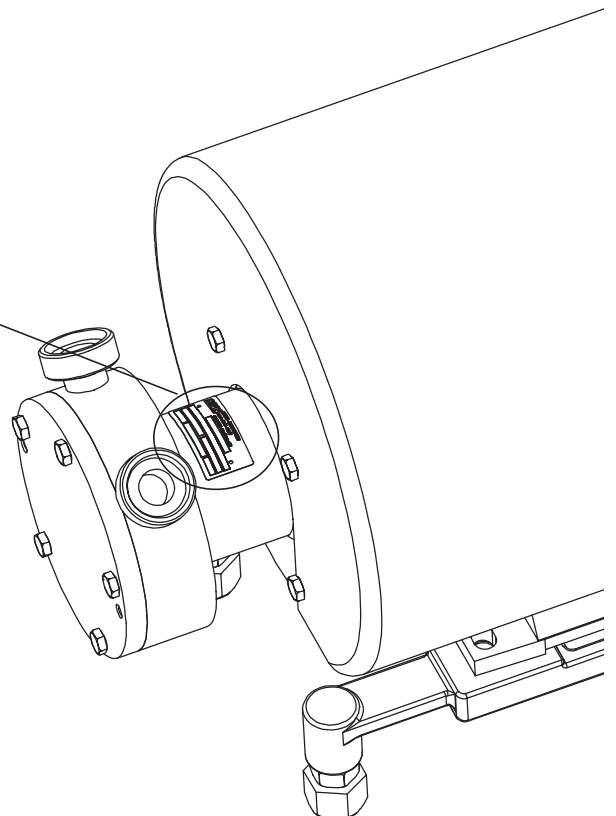







CSF Plate example

		POMPE-RACCORDERIA		
Montecchio E. - ITALY		Tel.0522-869911 http://www.csf.it		
○	Item. (1)	○		
Type (2)				
N° Matr. (3)	Anno (4)	(5)	r.p.m	
kW (6)	Volt (7)	Hz (8)		

1. System item provided by the client
2. Manufacturing series, size and execution
3. Serial number
4. Year of construction
5. Pump rotation speed
6. Installed power in kW
7. Motor voltage
8. Motor frequency



1.0 - SYMBOLS USED ON THE EQUIPMENT AND IN THE MANUAL

	CONSULT	Consult the instructions before carrying out a specific operation.
	THE USE AND MAINTENANCE MANUAL MUST BE READ	It is mandatory to read the Use and Maintenance Manual before performing any work on/with the machine.
	GENERAL SAFETY WARNINGS/INFORMATION	Indicates a warning or a note concerning key functions or useful information. Pay great attention to the text parts indicated by these symbols.
	WARNING! DANGER	Failure to observe the warnings may lead to serious injury and/or material damage.
	ELECTRICAL HAZARD	Only skilled personnel can carry out operations on electrical parts.
	MOVING PARTS HAZARD	Hazard caused by moving mechanical components during machine operation.
	DANGER: HOT SURFACES	Elements with a higher temperature than normal (xxxx zone).
	GENERAL PROHIBITION	Indicates a generic prohibition.
	DO NOT REMOVE SAFETY DEVICES	The removal of safeguards is prohibited.
	DO NOT SERVICE MOVING PARTS	Never perform maintenance on moving parts
	NO WATER JETS	Do not use high pressure jets of water to clean the machine.
	NO STEPPING	Do not climb onto the pump.
	NO SITTING	Do not sit on the pump.
	WEAR PROTECTIVE WORKWEAR	Mandatory protective equipment
	WEAR PROTECTIVE GLOVES	Hand protection must be worn: gloves
	WEAR SAFETY FOOTWEAR	Foot protection must be worn: safety footwear

2.0 - SAFETY WARNINGS

The pumps supplied are designed for professional use and are not intended to come into contact with the general public and minors.

Operators and maintenance personnel must read and comprehend the instruction manual.



Maintenance personnel must have adequate training and qualifications to carry out maintenance operations in compliance with safety standards.

Trainees may only carry out activities under the supervision of qualified, expert personnel.

 The equipment must not be tampered with. In the event of tampering, the manufacturer shall decline all liability concerning incorrect operation or any damage/injury caused by the product.

 Before using the equipment, make sure any situation which may represent a health and safety hazard has been eliminated.

Furthermore, it is essential for operators to take note of the warnings listed below:

	Do not use the machine when psychophysical state is impaired.
	Do not use the machine for purposes other than those for which it was designed.
	Do not remove or modify the signs affixed to the machine by the manufacturer.
	Do not try to remove or modify machine parts unless the operation is described in this manual.
	Never allow unauthorized personnel to work on or with the equipment.
	Do not stand or sit on the machine.
	Never leave the machine connected to power supplies when it is not being used/supervised.
	Never open electrical equipment enclosures when the machine is connected to the electrical power supply.
	Before starting the machine, make sure there are no unauthorized persons in the work area.
	Before starting the machine, make sure all safety devices are working properly.
	Wear the personal protective equipment prescribed in this manual, based on the operations being carried out.
	Keep the equipment as a whole and the work area clean, tidy and free of foreign objects.
	Internal inspections, modifications and repairs must only be carried out by qualified technical personnel authorized by the Manufacturer.
	Periodically carry out all the operations described in the specific paragraph on maintenance.
	In the event of anomalies or damage that could compromise equipment operation and safety, it must immediately be removed from service.
	Notify a supervisor if any operating irregularity occurs.
Make sure that all guards or other protective devices are in place and that all safety devices are installed and working effectively.	

When the pump is working the following occurs:



- Mechanical parts are moving.



- Pump casing, pipelines and articulations are under internal pressure. Therefore do not remove any safeguard or locking, do not loosen screws or clamps, as this can cause serious damage to persons or objects.

- Non-observance of inspection and maintenance operations can cause damages to persons and objects, especially when dangerous or toxic liquids are pumped



- Live parts: all operations on electrical parts must be performed by expert personnel who are able to observe technical standards and laws and are duly authorized by the plant manager.



- When pumping liquids at a temperature over 60°C, adequate protection and warning signals are required.

- Installation must ensure an adequate ventilation, in order to cool the engine, as well as enough space for maintenance operations.

2.1 - DANGER ZONES

The pump described herein has been designed and built to be safely used by operators.

All operators must be provided with suitable Personal Protective Equipment for performing the relative operations, i.e. safety footwear, protective gloves and workwear as better specified in § 2.4.



Should any unauthorized personnel come into the work area near the equipment, the operator must immediately stop all operations.

2.2 - SAFEGUARDS



Any failure to use the personal protective equipment indicated in this heading exposes operators to unnecessary hazards.

The employer must provide all machine operators referred to in this manual with the relevant PPE.

Machine operators must wear the following PPE:



Protective workwear;



Gloves providing protection against cuts, abrasion and burns, and safety footwear.

The employer, following risk assessment and taking into consideration variations in the production processes, may deem the use of additional PPE necessary.

Inspect the condition of the guards and relative fasteners on a regular basis (at least every 12 months).

If the guards are damaged, worn or have been removed or if the fastening devices have been removed or come loose, the user must immediately restore the condition of the guards and relative fastenings.

2.3 - OPERATORS AND RESPONSIBILITIES

SAFE WORK PROCEDURES

To reduce the potential consequences of the hazards set out in the previous headings, operators must abide by the following instructions:

- Always wear personal protective equipment as referred to in § 2.4;
- Supervise the danger zone, never start the machinery if other unauthorized persons are inside the danger zone or in the machine's immediate vicinity. Should any unauthorized person enter the aforementioned zone when an operating cycle is in progress, the operator must immediately stop all operations.



If particular maintenance, inspection or repair work on the machine requires the operator to completely or partially disable certain safety devices, it is his/her duty to restore operation of said devices as soon as the operations in question have been completed.

The responsibilities of the operators are given below:



To be done by the operator

- Use the machine for the purposes and in the operating conditions specified in this manual.
- Perform the periodic maintenance checks indicated in this User Manual and relative appendices.
- Regularly check elements subject to possible wear, in particular all moving mechanical parts (gear units, pumps) and piping containing pressurized fluids
- Check and keep all safety-related devices enabled and in good working order by periodically checking their operation (for example: regulators, control devices, indicators/gauges, etc.).
- Keep the operating area clean and tidy at all times.
- Stop the machine immediately if any malfunctions or anomalies arise that may affect safety during use.



To be done by the mechanical maintenance technician:

- Before carrying out any maintenance operations, always make sure the equipment has been disconnected from all power sources.
- Before carrying out any maintenance operations, to prevent inadvertent start-up by uninformed personnel, always put up one or more "MACHINE UNDER MAINTENANCE" signs in a clearly visible position.
- Always keep the maintenance area clean and dry.
- Never allow unauthorized personnel to work on or with the pump.
- Do not use petrol or flammable solvents as a cleaning detergent; always use authorized, non-hazardous commercial solvents only.
- Do not use compressed air to clean parts; if no other option is available, wear suitable eye protection with side shields and limit the pressure to a maximum of 2 bar.
- Never use naked flames as a light source when carrying out checks or maintenance operations.
- To avoid the risk of damaging the equipment and/or injuring personnel, after every maintenance or adjustment operation, always make sure no tools or foreign bodies are left on the machine or between moving parts.



Maintenance personnel are responsible for checking that all safety devices (guards, casings, etc.) have been correctly restored before authorizing machine use.

3.0 - GUARANTEE

All products manufactured by C.S.F. Inox S.p.A. are guaranteed to the purchaser, for one year from the date of purchase, against hidden defects in materials or manufacture, providing that they are installed and used according to instructions and recommendations of the manufacturer.

The guarantee does not cover wear parts or repairs for damage caused by improper use, abrasion, corrosion, negligence, defective installation, non-observance of inspection and maintenance operations, use of non-genuine spare parts, accidents or any work carried out by the purchaser designed to alter the machine's performance as indicated by the manufacturer.



Before returning to C.S.F. Inox S.p.A. any item to be substituted or repaired under guarantee, inform about the problem the Customer Assistance Office and follow instructions of the manufacturer. Returned items must be properly packed in order to avoid damages during transport and a technical report describing the defect and how it manifested itself must accompany the returned item/s.

Any item with a presumed fault should be returned to C.S.F. Inox S.p.A. at the customer's expense, accompanied by a Declaration of Decontamination (attached to page 31), unless otherwise agreed.

C.S.F. Inox S.p.A. will examine, repair and/or replace the returned piece and then send it back to the purchaser on ex-works basis.

Should the piece be found under warranty, no further costs will be owed by the purchaser. If, on the contrary, the fault is not found under warranty, all necessary reparations and replacements will be charged at normal cost to the purchaser.

C.S.F. Commercial parts incorporated in C.S.F. Inox products are guaranteed by their corresponding manufacturers.

3.1 - CERTIFICATION AND EC MARKING

The equipment was made in accordance with Machinery Directive 2006/42/EC and relevant EC directives applicable at the time of its placing on the market.

This Use and Maintenance Manual complies with Annex I point 1.7.4 of the aforementioned Directive as well as with standard UNI 10893 and ISO/IEC guide 37.



The list of Directives and standards applied is included in the Declaration of Conformity found in the manual of the pump supplied.

4.0 - GOODS TRANSPORTATION, RECEIVING AND TRANSFERRING

4.1 - TRANSPORT

The packings of all pumps manufactured by C.S.F. Inox S.p.A. are defined when placing the order. Unless prior arrangements have been made, goods are packed for transit conditions only and not for long-term storage; in case it should be necessary to store the pumps outside, you are requested to cover the pumps appropriately in order to protect the pneumatic parts of the motor from rain, dust, humidity etc.

4.2 - DELIVERY



On delivery of the supply it is essential to make sure that the packaging has not been damaged during transport so that any claims can be made immediately to the carrier.

Should any damage be ascertained, the following procedure must be observed:

- accept the goods with reservation
- Take photographic evidence of the damage
- notify the carrier of the damage sustained via registered mail with the photographic evidence attached.

4.3 - SITE PREPARATION

It is the user's responsibility to:

- Prepare the installation sites as prescribed by local legislation governing health and safety in the workplace



-Make sure the electrical power supply is compliant with the legislation in force and possesses an efficient earthing system.

LIGHTING

The machine installation site must have adequate natural and/or artificial lighting in compliance with the legislation in force in the country of installation.

Lighting must be uniform, guarantee good visibility in every part of the machine and must not create hazardous reflections to the operator. It must also be such that commands on the control panels and emergency stop buttons can be clearly seen.

FLOORING

Flooring must be of industrial standard, smooth and even. For pumps with bearings housing, after securing the base to the floor, correct alignment of the joints must be checked.

4.4 - TRANSFERRING

The personnel involved must have adequate qualifications and experience in handling and lifting operations.

Use suitable and certified equipment for lifting and handling the machine supplied.



Carry the packed pumps as close as possible to the place of installation by means of appropriate lifting devices and unpack them. During this operation take care, as unsteady parts could fall down. Packing materials must be disposed of in accordance with the relative regulations in force in the country of use (see chapter 16.0).

After unpacking the pump, use special lifting belts and move the pump-motor-set to the place of installation; never use the eyebolts on the motor to move the pump, as the eyebolts are for moving the motor only.

In versions complete with shroud, take the shroud off before moving the pump-motor-set, in order to avoid damages.



When lifting machinery the barycentre **MUST** always be in line with the lifting point

***N.B.:** check the weight of the machine indicated on the data sheet attached to the instructions.

Observe all relevant local health & safety regulations.

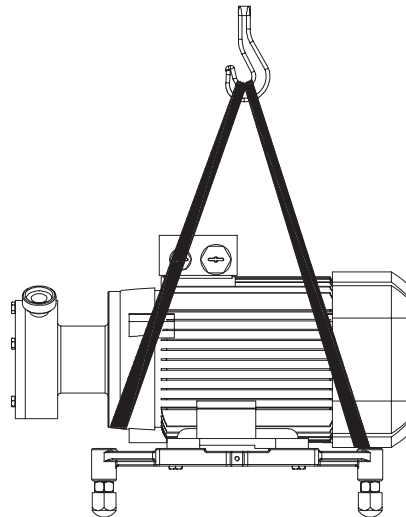

5.0 - RETURNS

- Empty the pump correctly
- Wash and thoroughly clean the pump, especially in the case of harmful or explosive liquids
- Thoroughly dry the pump
- A duly compiled Declaration of Decontamination must accompany the pump (see page 31).

6.0 - DESCRIPTION

Pumps in the CP series have been designed to operate with very low flow rates and high heads. They are ideal for handling clean liquids with no abrasive particles or suspended solids and with a maximum viscosity of 250 cP.

All models feature fittings in accordance with DIN 11851 standards (unless otherwise requested). The front cover is easily opened to facilitate cleaning operations and speed up maintenance operations. The seal is mechanical with standardized seats in compliance with EN12756 and ISO 3069; component materials are selected based on the liquid being pumped.

Built in a close-coupled version, they are assembled with three-phase electric motors, B34 construction type, with IP 55 protection rating, unless otherwise specified in the order.

6.1 - TECHNICAL DATA

- Maximum operating pressure: 16 bar up to 100°C
- Temperature range: -10°C ÷ 100°C

The operating temperature range is determined by the type of mechanical seal and the material of the elastomers used.

If there is any need to use the pump with different performance data and product characteristics to those indicated at the time of ordering, contact C.S.F. Inox S.p.A. to make sure the pump is suitable for your requirements.

ROTATION DIRECTION

Clockwise as seen from the motor side. The pump is not reversible:

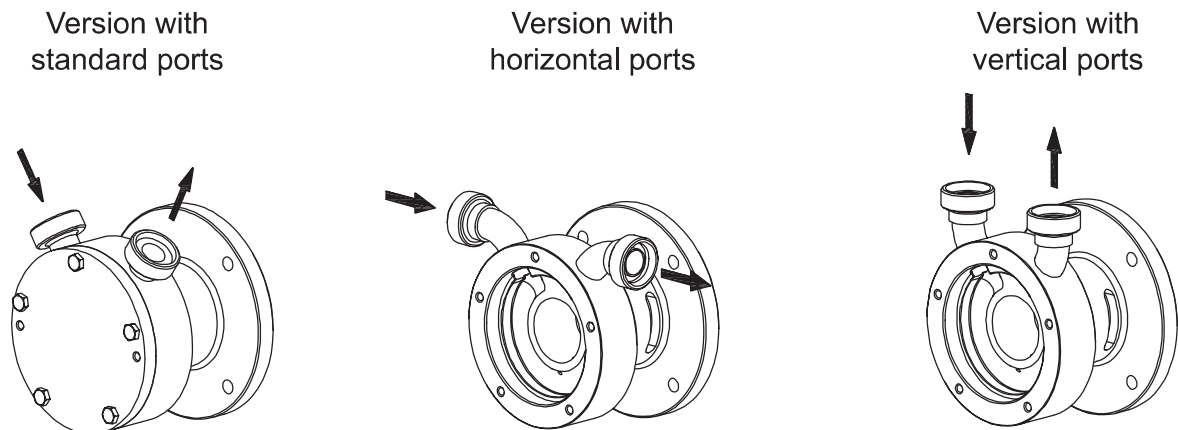

6.2 - SOUND PRESSURE LEVEL

The sound pressure level of CP pumps is the following (see table):

Noise index dB(A)	Pump type
<75	CP 15 - CP 25

The measurement has been made by means of a phon-meter placed at 1 m distance from the pump and at a height of 1.6 m from the ground.

Preliminary condition is that the pump is fixed correctly; the above mentioned values do not take into account external noise sources (e.g. valves, abrupt hydraulic deflections).

6.3 - WEIGHTS

The weight may vary depending on the execution, make and/or model of the motor installed. For information on the weight of the pump, see the data sheet provided as an appendix to the instructions.

7.0 - INTENDED USE

7.1 - INTENDED USE

The machine and/or parts thereof must never be used for purposes other than those foreseen in this Use and Maintenance Manual. Observance and strict compliance with the conditions of use, repair and maintenance, as specified by the Manufacturer, constitute essential aspects of the equipment's intended use.

The equipment was designed and built for the uses indicated in chapter 6.0 "Description".

7.2 - PROHIBITED USE



The machine **MUST NOT** be used:

- By personnel other than those indicated in the previous heading;
- For purposes other than those described in Chapter 6.0 and the previous paragraphs;
- With materials and fluids different to those indicated in the 'intended use' section of the pump manual;
- In atmospheres that are potentially explosive and/or constitute a fire risk;
- If it has not been installed correctly;
- If there are power supply faults;
- In the event of serious maintenance shortcomings;
- The pump must always be used in an environment appropriate to the level of protection of the motor. Always check this on the motor plate before installation



THE PUMP MAY NOT BE USED IN ENVIRONMENTS WHICH REQUIRE A HIGHER LEVEL OF PROTECTION OR A HIGHER SPECIFICATION MOTOR OR ELECTRICAL PARTS.

Components complying with relative safety standards must be used.

- In ambient conditions different to those indicated in Chapter 4.0.



For any use of the equipment different to that indicated herein, the manufacturer reserves the right to review the warranty conditions and validity of the equipment certification.

8.0 - INSTALLATION, HOOK-UP AND START-UP

The equipment is built and assembled on the Manufacturer's premises and is then delivered to the customer.

8.1 - HANDLING AND LIFTING PRECAUTIONS

Handling must be carried out in a manner that avoids any damage.

- When handling with a crane, always rig up the load using at least two ropes/belts.
- When handling with a forklift, the length of the tines must always be greater than the width of the machine and protrude from the opposite side of the load.
- All protective devices, guards and casings must be correctly secured in place.
- When transporting the machine, parts must be protected against possible impact and strain (pay particular attention to electrical components).
- The equipment must be lifted as per the procedures described in chapter 4.0.
- Secure cables and adequately protect connectors.

8.2 - TRANSPORT AND POSITIONING

The machine must be installed in observance of the minimum clearances required for safe use and comfortable manoeuvring of personnel and handling equipment.

The machine **MUST** be pushed manually, it must not be towed or pushed by any other means. It must be moved on flat and sound surfaces. It must not be moved on ramps or slopes.



It is important to ensure that the machine is well levelled to avoid vibrations during operation.

Maximum permissible slope of floor: $\pm 2^\circ$.

For further information, see chapter 4.0 on page 12.

8.3 - SUCTION AND INFLOW CONDITIONS

(NPSH = Net Positive Suction Head)

NPSHa (NPSH available)

In order to ensure that pump operation is free from cavitation, it is essential to observe the maximum permitted suction lift **ha geo max** or the minimum allowable head **hc geo min**.

NPSH of system (available NPSH)

The centrifugal pumps can operate correctly only if vapour has not formed inside. For this reason the static head at the reference point for the NPSH is the centre of the impeller, that is the point of intersection of the pump shaft axis with the vertical plane that passes through the external points of the blade inlet corners.

NPSHr (required NPSH) is the value required by the pump, expressed in metres, obtained from the performance curve. In practice 0.5 m should be added to this value as a safety margin.

8.4 - PIPING

In order to prevent the creation of harmful stresses, the suction and discharge pipes must be connected to the pump ports without the use of force. These pipes must also be supported independently avoiding causing stresses on the pump. The internal diameter must be the same size as the pump connections. It must in any case not be smaller to avoid head loss and/or poor performances.

Always use elbows with large radius. If the pipe diameter changes along the line, use reduction cones, choosing the ones that are most suitable to avoid any formation of air pockets (Pict.1).

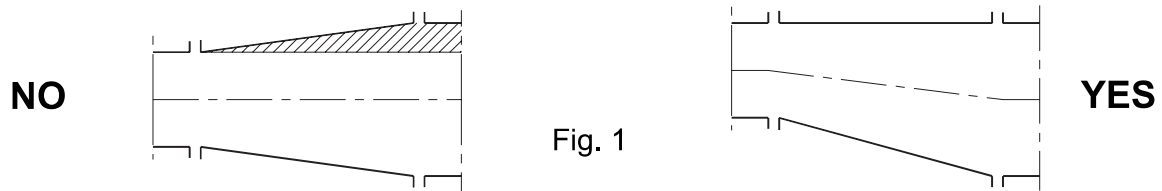

Fig. 1

The suction pipe must be as short as possible and rise as it moves towards the pump if it is sucking from a tank. If on the other hand the pump is below the level of the liquid, the pipe should descend slightly. If the pump is used for transporting hot liquids, fit expansion joints to compensate any expansion of the piping. The maximum velocity of the liquid in the suction pipe must not be greater than 3 m/s. Velocities between 1 and 2 m/s are recommended. The suction pipe must be designed in such a way as to prevent air from entering the pump.

For this reason, when sucking from a tank located at a lower level, the pipe must reach below the free surface of the liquid. In order to prevent the formation of vortices and avoid the risk of sucking in air, always keep a minimum head at the pipe inlet ($h_{min.}$) equal to at least the dynamic head plus a safety margin of 0.1 m.

$$h_{min.} = \frac{V a^2}{2g} + 0,1 \quad \begin{matrix} h_{min} = m \\ V = m/s \end{matrix}$$

In order to prevent the formation of vortices when it is not possible to observe the values of minimum available head, it is possible to fit crosses in the piping. This system is suitable even for tanks with a positive head.

Avoid creating obstacles which could increase suction losses disrupting smooth fluid flow. Make sure that there are no restrictions, sharp turns or tight elbows on the discharge line, since these increase disturbance.

During electro-welding work never use the pump as an earthing point and make sure the current does not flow through the bearings.

Before using the pump, make sure the tank and piping are clean and examine the inside of the pump before connecting the piping.

8.5 - ELECTRICAL CONNECTION



Make the electrical connection only after the hydraulic connection has been completed; set up the motor control system in conformity with the technical standards and regulations in force (EN 60204-1): in particular a manual electric power switch must be installed with adequate current switching capacity; devices for overcurrent and overload protection (e.g. fuses, automatic switches, etc.) must also be fitted, plus, if necessary, a device to prevent accidental restarting. Check that the main frequency and voltage and the available power are suitable for the motor installed. All the material used for the electrical connection (cables, cable clamps, switches and shielding) must have a suitable level of protection for the environment in which it is installed. Be sure to use cables of sufficient cross-section for the current shown on the motor plate so as to prevent them from overheating.

Before doing anything else, make the motor's earth connection, using the terminal on the motor and a cable of sufficient cross-section. The cables may be connected to the terminal board using either a delta or star arrangement. Follow the data given on the motor plate for the main voltage, as shown in the diagram in pict.2; when starting, the motor's current absorption increases briefly to 5-6 times the nominal value. If the mains supply is unable to sustain this increase in absorption, use a star-delta starter or other kind of device (e.g. an autotransformer).

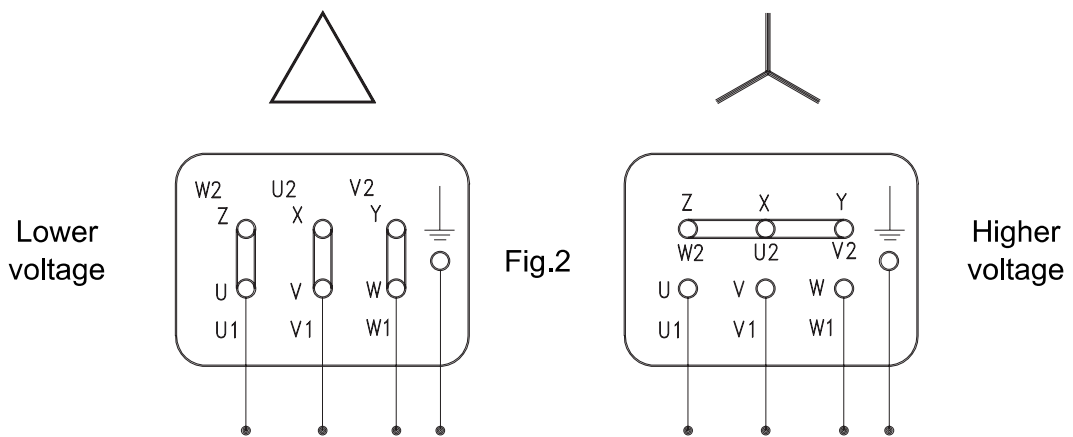

C.S.F. Inox S.p.A. will accept no responsibility for damage to property and/or injury to persons caused by failure to comply with the technical standards and regulations in force.

9.0 - OPERATION

9.1 - PRELIMINARY OPERATIONS BEFORE START-UP

Before starting the machine, a series of checks and controls must be carried out to prevent any errors or accidents during the start-up phase.

- Check that the pump has not been damaged during transport, installation and handling.
- Check that all fixed guards are securely attached to the machine.



If ever the equipment does not appear suitable for correct and safe operation, **TAKE IT OUT OF SERVICE** until damaged parts have been repaired or replaced.

- Check that the pump turns freely under hand pressure;
- Check the pump cover; it must be securely tightened and not easily unscrewed by hand.
- Check the direction of rotation (clockwise as seen from the motor side).

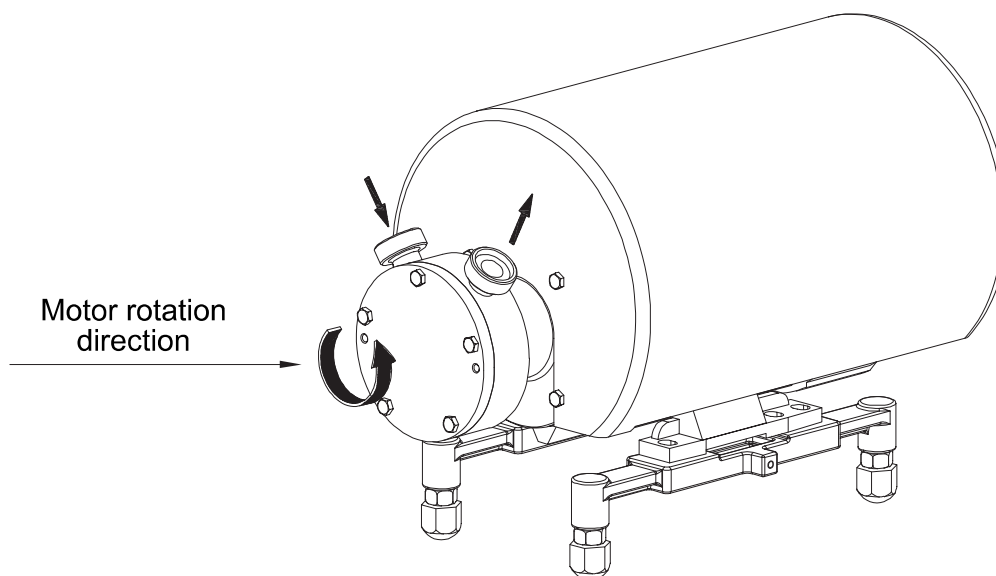

The suction pipe and the pump must be filled with liquid. There are two possible cases:

- a) Before activating the pump, suction and delivery valves must be opened until the pressure gauge on pump outlet shows a pressure corresponding to the positive suction head.
 - b) If the sealing chamber is to be cooled, open the cooling fluid supply and adjust the flow.
- After carrying out the preliminary operations, then close the discharge valve completely and make sure that the suction valve is completely open.
 - Start the pump and check once again that it rotates in the right direction.

OPERATING CHECKS

- If the pump does not generate the required discharge head rapidly, stop and repeat the priming operations.
- If the delivery gate valve is opened more than necessary, i.e. further than the specified working point, and the pump is operating with a lower discharge head than that required, there will be an increase in delivered capacity and absorbed power. If this occurs, throttle the discharge until the required head and capacity values are obtained.
- The pump must operate smoothly and without vibrations.
- Do not operate without liquid and in any case avoid prolonged operation with the discharge gate valve closed.
- Check that the suction liquid level is always sufficient to grant an adequate energy load for normal operation of the pump.
- Mechanical seal: check that there is no leakage along the shaft.

9.2 - EXTENDED STOP

If a period of prolonged inactivity is envisaged, refer to the storage operations described in § 4.3 (page 12) and take the following measures:

- Disconnect the electrical power supply;
- Disconnect the suction and delivery hoses from the pump;
- Store the machine in an indoor location, applying the brakes on the wheels;
- Grease any unpainted parts and make sure the machine does not come into contact with corrosive substances;
- Protect the machine from knocks and mechanical stress;

When stopping the pump for a longer time, empty the pump completely and wash it accurately in order to avoid the formation of scales and/or encrustations.



To return the machine to service after a prolonged period of inactivity, perform the initial controls for first start-up (previous heading).

9.3 - CLEANING THE PUMP

The pump does not require any special washing procedures. The washing cycles normally used for the plant in which it is installed are quite satisfactory. When using the pump for liquids that tend to harden or crystallize, always make sure it is washed before taking the machine out of operation. This will ensure durability of the seal and of the pump itself. It is the user's responsibility to ensure that the washing liquids are compatible with the process liquid and the pump.

For correct cleaning of the pump, please see the washing procedures described in heading 15.0 on page 29.

10.0 - SPARE PARTS

10.1 - MAIN PARTS SUBJECT TO REPLACEMENT

Detail	Pump type	
	CP 15	CP 25
* Mechanical seal EN 12756 - ISO 306	D.20	D.20
O-ring seal	OR 4325	OR 4387

* NB: The type and materials of the seals are identified in the enclosed technical parts list.

10.2 - RECOMMENDED SUPPLY

RECOMMENDED SPARE PARTS FOR TWO YEARS OF OPERATION ACCORDING TO THE NUMBER OF PUMPS INSTALLED - VDMA STANDARDS					
Denomination	NUMBER OF PUMPS (including reserve)				
	1	2	3	4	5
MECHANICAL SEAL	1	2	3	4	4
CASING O-RING SEAL	2	3	5	6	7
IMPELLER LOCKING NUT O-RING SEAL	2	3	5	6	7

C.S.F. Inox declines all responsibility for damage or injury resulting from the use of non-original spare parts.

11.0 - OPERATING MALFUNCTIONS



All troubleshooting operations must be carried out by authorized and qualified personnel.

IMPORTANT: before resetting the machine, make sure that the cause behind the emergency stop has been eliminated.



Never carry out maintenance and/or repairs that alter the safety of the machine.

The purpose of this chapter is to provide solutions for the problems or malfunctions that are most likely to occur.

The list below is not exhaustive, if necessary contact the Manufacturer or relative service centre (if present).

We are herewith listing some of the possible working irregularities which may occur using the pumps, with a table helping to find out the possible causes and how to solve the problem.

The pump does not start

- Air has got into the suction piping; check the gaskets on the fittings and tighten them properly.
- Suction pipe not submerged in the liquid.
- Increased play between impeller/cover and impeller/ casing, check and rectify.
- No liquid in the pump; add liquid.
- Reduce suction losses, reduce suction height.
- Formation of air pockets; eliminate them by installing an air bleed valve on the delivery line if necessary.

Zero flow rate

- Pump not primed; (see previous list).
- Incorrect direction of rotation.
- Suction port blocked.
- Shut-off valves (if present) closed.

Insufficient flow rate

- Greater system back pressure in delivery; increase piping diameter.
- Air intake via the mechanical seal; check the condition of the seal.
- Liquid viscosity higher than specified in the order; contact the manufacturer.
- Increased play between impeller/cover and impeller/ casing, check and rectify.

Loss of head

- System back pressure in delivery has dropped, throttle the delivery pipe.
- Increased play between impeller/cover and impeller/ casing, check and rectify.

Increase in absorbed power

- Flow rate is lower than envisaged.
- Greater pump rotation speed
- The impeller is not turning freely, check.
- Viscosity and/or specific weight are higher.
- Bearing no longer in good condition.

Increase in absorbed current

- The power required has increased (see previous point).
- Mains voltage value decreased.

12.0 - MECHANICAL SEALS

All C.S.F. self-priming pumps of the CP series are fitted with unified mechanical seals according to EN 12756 - ISO 3069 standards, in order to grant the interchangeability (subject to verification of axial space). The type of mechanical seal and material are chosen according to the liquid to be pumped.



Before using the pump for any liquids other than those specified when selecting and ordering, ensure that mechanical seals and gaskets are suitable for the new product.

MATERIAL CODES

METALS

X1 - Stainless steel Inox AISI 316L

RESINS

C1 - Normal PTFE

F1 - O-RING FEP

ELASTOMERS

P1 - Nitrile (NBR)

E1 - Ethylene propylene (EPDM)
FDA-3A-USPVI)

Y3 - FPM for high T

B1 - Silicone

W1 - FFPM-FFKM

METAL OXIDES

2 - Alumina ceramic

CARBONS

V1 - Normal carbon

V2 - Special carbon

METAL CARBONS

X3 - Hard metal welded on stainless steel (TUC)

R1 - Integral hard metal hard metal (TUC)

K1 - Integral silicate carbon (SIC)

EXECUTION "W"

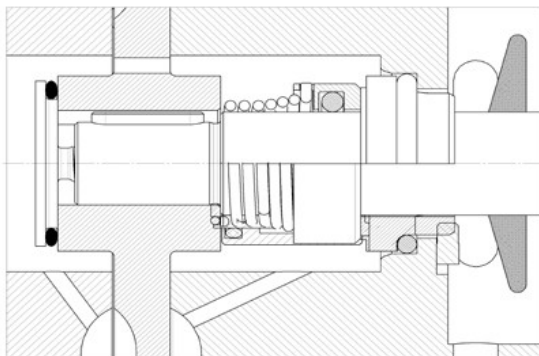

INTERNAL MECHANICAL SEAL

Standard execution envisages the installation of an internal mechanical seal, immersed in the product, housed behind the impeller in a special chamber in order to guarantee the right lubrication conditions.



EXECUTION "WH"

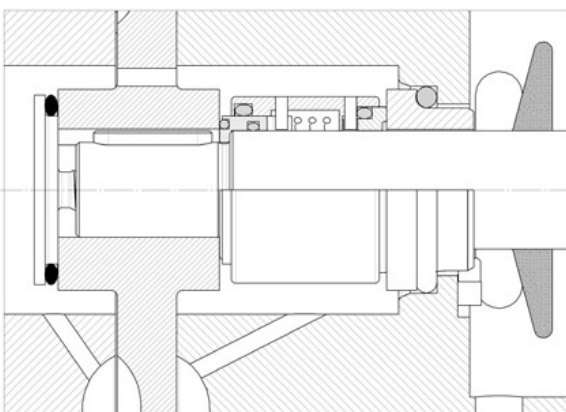

INTERNAL MECHANICAL SEAL

Envisages the installation of an internal mechanical seal, immersed in the product. Protected and balanced execution with easy to wash and clean linear profiles, suitable for use in health and food product applications.



EXECUTION "Q"

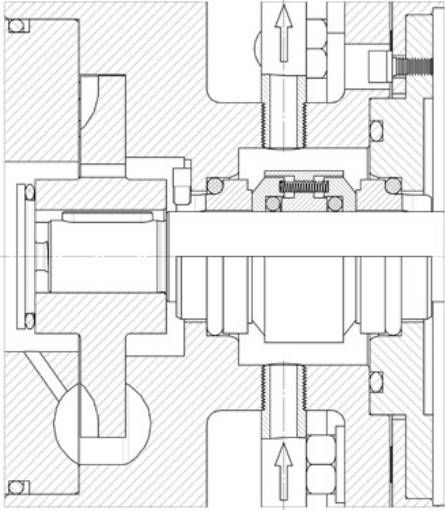

DOUBLE FLUSHED MECHANICAL SEAL

Double mechanical seal with circulation of washing and cooling liquid. It is used with products that tend to crystallise, to glue, to harden, to be highly corrosive, to reach high temperatures and whenever the internal single seal life is limited.



Assembly value X = 17.5 mm

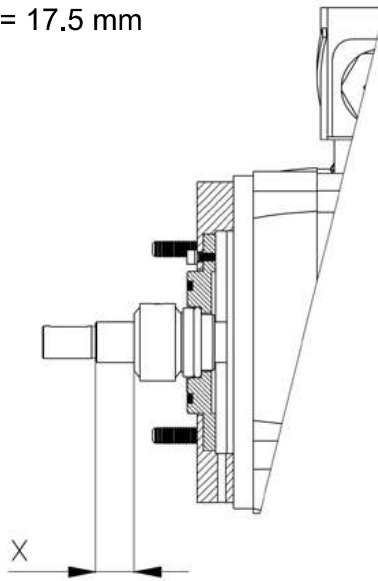

13.0 - DISASSEMBLY

13.1 - DISASSEMBLY OF CP PUMP "W" EXEC.

1. Remove the screws (45) and take the shroud (44) off the motor (50). Loosen the two upper screws (40) and lift up and remove the eccentric closure casing (43).

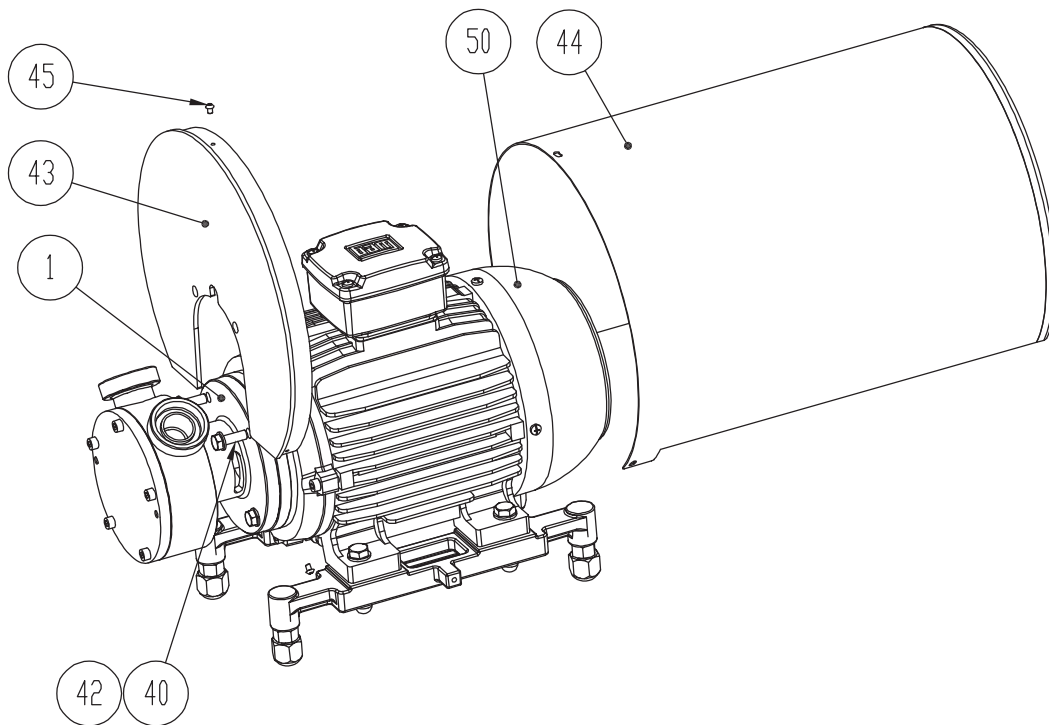

2. Remove the screws (38) and take off the the cover (7) and its OR (16). Proceed by unscrewing and removing the impeller locking screw (14) with O-ring (15) (this is done using a pneumatic or fixed wrench, blocking the impeller or the shaft on the motor side).

N.B. (part. 14) hexagonal impeller locking screw CH = 34 mm.

Remove the impeller (6).

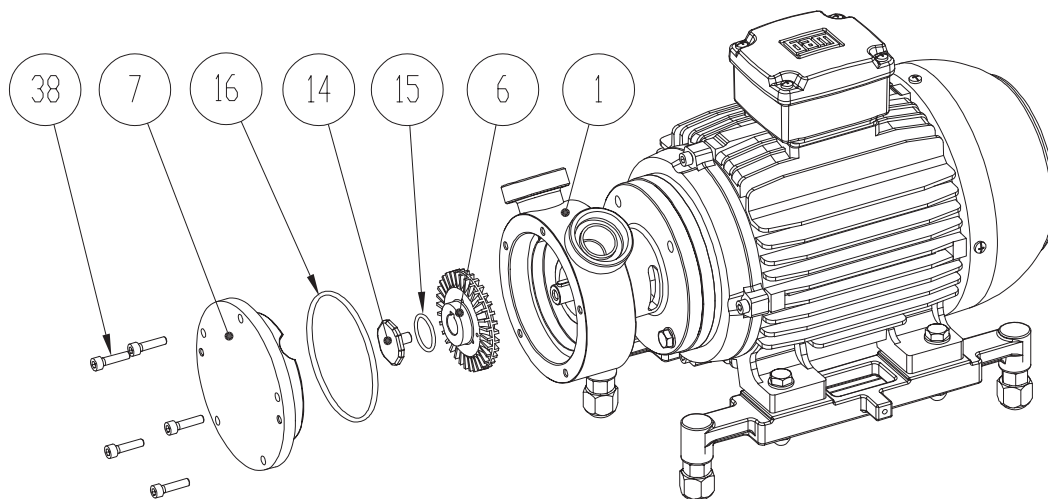

3. Remove the key (24), the shims (19) and the rotary part of the mechanical seal (13).
4. Separate the pump casing (1) from the motor (50) by removing the screws (40) and extract the fixed part (13) of the mechanical seal from its seat. Remove the splash guard ring (27) from the motor (50).

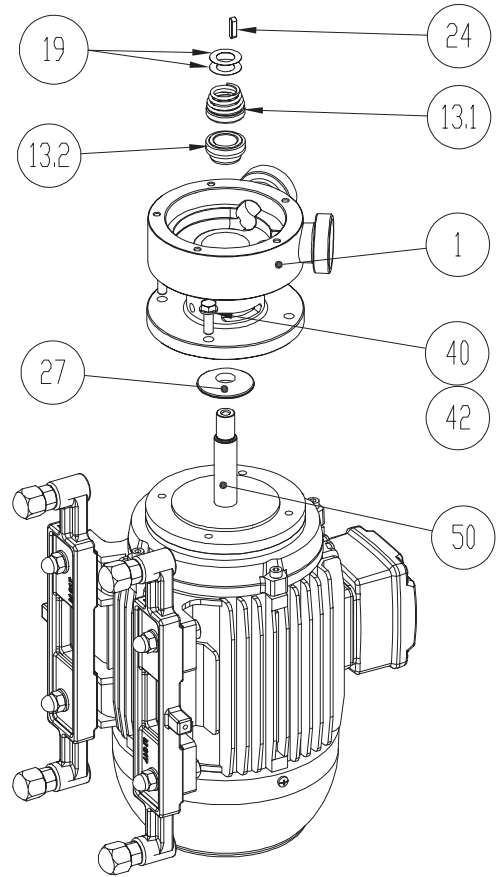

5. Position the motor vertically and take off the supports (82) by removing the screws (52).

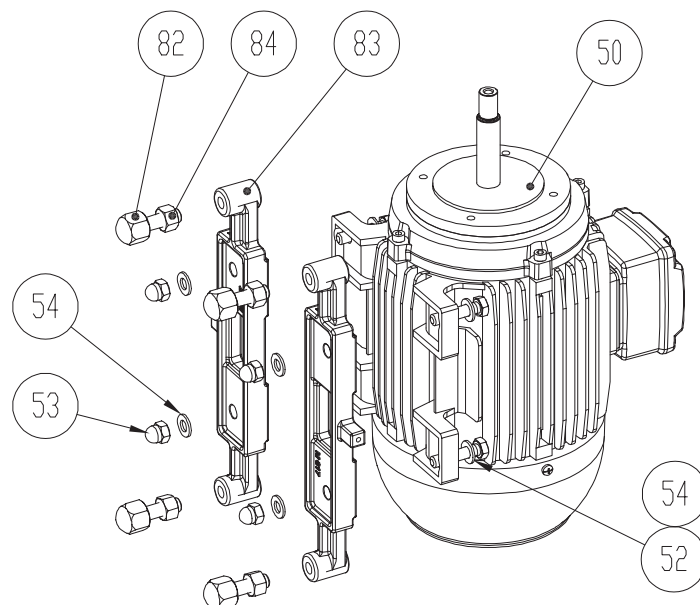

13.2 - DISASSEMBLY OF CP PUMP "Q" EXEC.

1. Perform the operations 1 - 2 as in the previous heading 13.1.

2. Remove the key (24) and the shims (19). Separate the casing (1) from the motor (50) by unscrewing the flushing pipes (104) and removing the nuts (86) and relative washers (87). Extract the fixed part of the mechanical seal (13.1) from the casing (1).

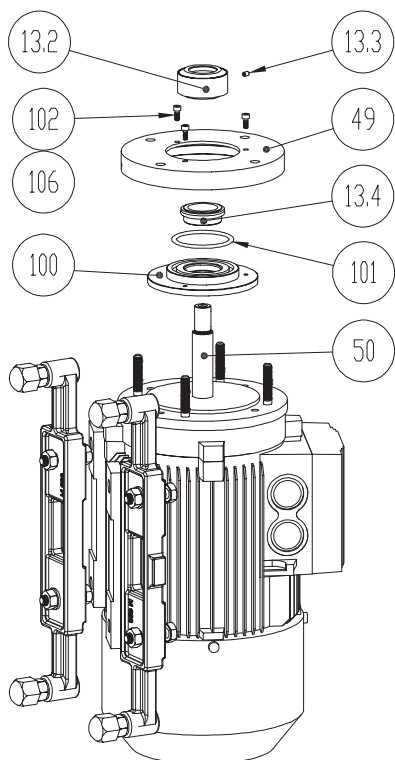
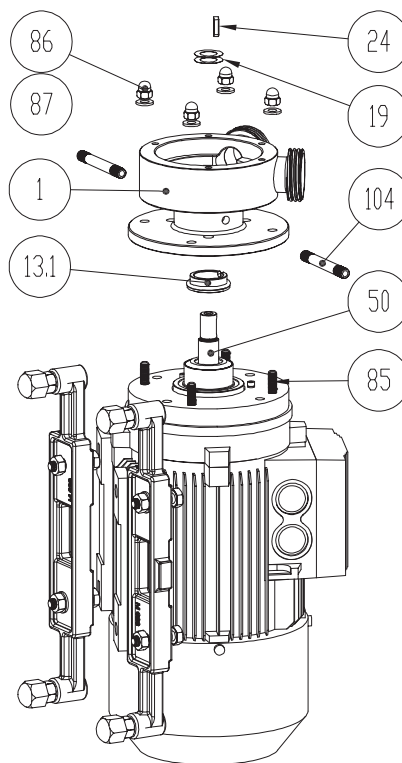

3. Slacken the locking grub screws (13.3) and slide the rotary part (13.2) off the shaft (50). Separate the intermediate flange (49) from the seal cover (100), by removing the screws (102) and relative washers (106), remove the OR (101) and the fixed part (13.4) from the cover (100).

4. Carry out operation 5 as described in the previous heading 13.1.

14.0 - PUMP ASSEMBLY

14.1 - ASSEMBLY OF PUMP "W" EXEC.

Observing the positioning of the seals as described in chapter 12, carry out the disassembly operations in reverse order in relation to the previous chapter, heading 13.1, thus obtaining the sequence of steps needed to assemble the pump.

N.B.: Refer to the images below to ensure the assembly allowances are observed with the aid of shims (detail 19).

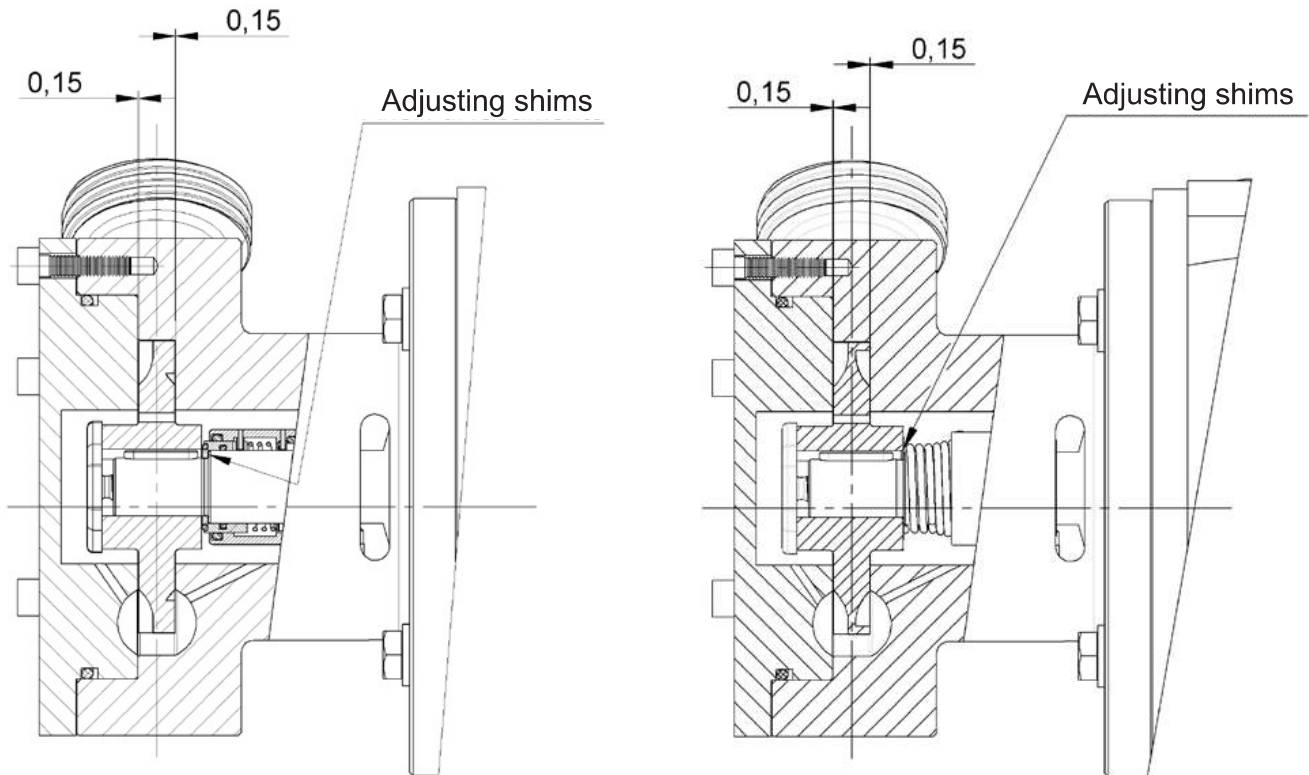

Exec. with "WH" seal

Exec. with "W" seal

14.2 - ASSEMBLY OF PUMP "Q" EXEC.

Observing the assembly value X for positioning the seals as described in chapter 12, carry out the disassembly operations in reverse order in relation to the previous chapter, heading 13.2, thus obtaining the sequence of steps needed to assemble the pump.

14.3 - IMPELLER NUT DIMENSIONS

Pump size	Thread size	Tightening torque [Nm]
CP 15	M 8 (CH 34)	18
CP 25		

15.0 - CLEANING PROCEDURE

Use suitable personal protective equipment during cleaning operations.

15.1 - EXTERNAL CLEANING

Periodically clean the external parts of the pump and motor to prevent dust and deposits building up which could reduce heat dissipation and/or damage the external surfaces.

15.2 - CLEANING OF INTERNAL PARTS

Before performing any maintenance work which requires disassembly of the pumping parts, carry out internal cleaning by running the pump with washing fluids compatible with the pumped fluid and the pump materials.

If the pump needs to be sent back to C.S.F. Inox for maintenance/repair work, fill in the Declaration of Decontamination (page 31).

15.3 - CLEANING OF FOOD-CONTACT PUMPS



When a pump is intended to handle food products, it must be perfectly clean before it is put into operation.

This can be achieved by performing a CIP (cleaning in place) washing procedure or by disassembling the pumping part for manual cleaning.

It is up to the user to choose the most suitable cleaning method based on the type of product being handled and the processing stage in which the pump is used.

In the case of CIP, the user is responsible for selecting the necessary detergents, operating temperatures and detergent product concentrations based on the type of food product being pumped.

The duration of each step in the CIP washing cycle depends on the type of dirt/residue that needs removing.

It is important to check the compatibility of the chemical products and operating temperatures used in the washing cycle with the pump components specified in the data sheet (elastomers, mechanical seal).

The cleaning process must also be carried out in the following situations:

- Before a long period of non-use
- Before any disassembly operations for maintenance work and after subsequent reassembly if worn parts have been replaced
- Before restarting after a long period of non-use.
- At intervals established by the user based on the characteristics of the pumped products and the type of process in which the pump is used, in order to guarantee food product hygiene.

It is the user's responsibility to verify the effectiveness of the cleaning procedure adopted.

Alkaline detergents:

A sodium hydroxide/water solution may be used at concentration 1-3% at a temperature of 70-90°C; a surfactant could be added to increase the rinse cleaning.

Acid solution:

It is used to neutralize alkaline residual and for the passivation of the stainless steel surface; a solution of nitric acid at 1-2,5% could be used at ambient temperature up to 45°C.

Other acid solution could be: citric acid and water (0,5-3% at 70°C) and phosphoric acid at 0,5% with a temperature up to 45°C (with inhibitor of corrosion).

15.4 - CIP WASHING PROCEDURE

A typical example of a CIP washing procedure is described below:

- a) Prerinse with cold water (15-25°C) for 10-15 minutes to remove any residue.
- b) Warm prerinse with water at 45-60°C for 10 minutes.
- c) Rinse with alkaline solution at 70-80°C for 20-30 minutes.
- d) Intermediate rinse with water (warm or cold) up to 60°C for 5-10 minutes.
- e) Rinse with acid solution like nitric acid for 10 – 15 minutes at ambient temperature.
- f) Final rinse with cold water for 10-15 minutes or until any traces of cleaning agent have been removed.

Warnings:

- a) During the CIP process there are thermal expansion: take care that there are not rapid temperature variations.
- b) Chemical agents at high temperature can cause potential health risk: respect the safety regulation and use protection devices.
- c) Control the concentrations and temperature of chemical agents during the CIP.
- d) Store the cleaning agents in compliance with the safety regulations.

Sterilization:

If requested, a sterilization can be carried out by means of hot water or steam; the pump must be stopped during the sterilization process with steam.

See the admissible temperature for sterilization depending on gasket compound:

Elastomers / temperature limits	Steam/hot water	Chemical bactericidal
EPDM	121°C	82°C
FPM/FKM	149°C	82°C

Impeller cap nut cleaning and sterilization:

- 1) The dismantled nut should be cleaned before assembling (internal threads).
- 2) Clean the nut with ultrasound washing system or detergent and rinsing with clean water.
- 3) Sterilize the cap nut using steam at 143°C for 30 minutes in an autoclave or using chemicals (for example glutaraldehyde-based solutions). Do not use chlorine solutions because stainless steel could be damaged by corrosion.

DECLARATION OF DECONTAMINATION

In observance of the legal provisions in force and to protect the health and safety of our personnel, you must fill in, sign and return this declaration to us before we can process your order. Please make sure that the same declaration is attached to the outside of the packaging.

Shipping address: C.S.F INOX S.p.a. Strada per Bibbiano, 7 42027 Montecchio E. (RE), Italy	For information contact:
---	---------------------------------

***Mandatory fields**

* Pump: _____ *Serial Number: _____

Commissioning date: _____

* Field of application: _____

Fluid handled: _____

Process data: Temperature: _____ [°C] Pressure: _____ [bar]

Flow rate: _____ [m³/h] Viscosity: _____ [mm²/s]

*** Product and warnings:**

	Product/ concentration	Flammable	Toxic	Corrosive	Hazardous/ irritant	Other**	Harmless
Processing product		<input type="checkbox"/>	<input type="checkbox"/>	<input type="checkbox"/>	<input type="checkbox"/>	<input type="checkbox"/>	<input type="checkbox"/>
Cleaning product		<input type="checkbox"/>	<input type="checkbox"/>	<input type="checkbox"/>	<input type="checkbox"/>	<input type="checkbox"/>	<input type="checkbox"/>
Parts cleaned by		<input type="checkbox"/>	<input type="checkbox"/>	<input type="checkbox"/>	<input type="checkbox"/>	<input type="checkbox"/>	<input type="checkbox"/>

**** Explosive; oxidant; harmful for the environment; biological risk; radioactive.**

Please mark the appropriate warning, include the material safety data sheet and, if necessary, any further specific warnings.

*** Reason for returning item/s:**

* Particular safety precautions for further handling are not required

* The following precautions are required in the case of cleaning liquids, fluid residues and disposal:

Company details:

Company: _____ Phone no.: _____

Contact: _____ Fax: _____

Address: _____ Email: _____

Your order number: _____

‘ We hereby certify that this form has been filled in to the best of our knowledge and in accordance with the legal provisions in force. Furthermore, we certify that the parts have been carefully cleaned and to the best of our knowledge are free from residues in quantities which could be deemed harmful. ’

Place, date

Name, department

Signature

.....

16.0 - WASTE DISPOSAL AND DECOMMISSIONING



The pump, complete with electrical drive system, is a plant component which must be disposed of in accordance with regulations governing the disposal of waste derived from professional electrical and electronic equipment.

Neither the pump nor any of its parts may be disposed of with household waste.

16.1 - PACKAGING MATERIALS

The packaging material consists of wooden or cardboard boxes, polyethylene shrink-wrap covers and polyurethane foam, galvanized steel screws, polyester belts.

Wooden or cardboard boxes and screws can be recycled or sent to authorized waste disposal facilities.

The remaining packaging materials must be sent to authorized waste disposal facilities.

16.2 - WASTE RESULTING FROM MAINTENANCE OPERATIONS

All materials replaced during maintenance operations must be disposed of in compliance with current regulations and sent to an authorized waste disposal facility.

Consult the pump's bill of materials, supplied with this manual, to identify the materials used to make the replacing components.

All replaced metal parts must be sent to metal recycling centres; plastic or elastomeric parts and spent lubricants must be disposed of at authorized waste disposal facilities.

16.3 - DISPOSAL OF THE PUMP

For disposing the pump please observe the following instructions:

- disconnect electrical and hydraulic connections according to technical rules and laws in force.
- Disassemble all components of the pump for separate dismantling; wash the components and clean the structure accurately.

The main components of the pump are made from the following materials:

- Pump casing, cover, impeller, shaft, impeller nut: AISI 316L stainless steel (for special alloy pumps, see the bill of materials)
- Elastomers/Polymers NBR-EPDM-FKM-FFKM-PTFE
- Support and external parts: AISI 304
- Other components: composite mechanical seals, stainless steel and elastomers, ball and roller bearings.
- Motor: Aluminium - Cast Iron - Copper (consult the manual supplied by the manufacturer)
- Spend oils and greases

For further details, consult the pump's bill of materials, supplied with this manual, to identify the materials used to make the various components.

There are no components containing asbestos, cadmium or lead, PBB or PBDE.



The components of the pump should be properly got rid, according to the corresponding rules in force in receiver's country.



DECLARATION OF CONFORMITY

The company: **C.S.F. Inox S.p.A.**
based in: **Strada per Bibbiano, 7
Montecchio Emilia (R.E.)
ITALIA**

hereby declares, under its sole responsibility that the pump:

CENTRIFUGAL PUMP

Type XXX

Serial no. XXX Year XXX

CE Declaration of Conformity (Ann. II.A, 2006/42/EC)

to which this declaration refers, is in conformity with safety requirements according to Directive 2006/42/EC.

Name and address of the person authorized to compile the technical file:
C.S.F. Inox S.p.A. Strada per Bibbiano 7 - 42027
Montecchio Emilia (RE) ITALY

Applied Regulations:

EN 12100 2010

EN 809 2009

Food products-contact suitability declaration

is made with materials suitable to come in contact with food according to the regulation (EC) no. 1935/2004.

2014/35/EU : electrical material intended for use within certain voltage limits.

Montecchio Emilia, XXX

The Chairman Mr. Rolando
Paterlini



DISCOVER THE WIDTH OF OUR RANGE!

Colly Flowtech offers one of the market's widest ranges of flow technology for industry. We offer everything from pumps, homogenisers, industrial hoses and heat exchangers to stainless steel piping systems, valves, couplings, quick-connect fittings and filter solutions. With both standard products and customised solutions, we help industry create safe, efficient and reliable flow systems.

PUMPS



HOSES



**STAINLESS STEEL
PIPES & FITTINGS**



**SINGLE USE
SOLUTIONS**

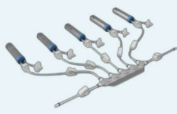

QUICK COUPLINGS



VALVES



HEAT EXCHANGERS



HOMOGENISERS



**SPARE PARTS &
SERVICE**



TANK EQUIPMENT



FILTERS



**GASKETS &
GASKET CARE**



DISCOVER OUR FULL RANGE OF PRODUCTS AT COLLYFLOWTECH.SE

Since 2007, we have combined local presence, high service levels and strong expertise to deliver comprehensive flow solutions to the manufacturing industry across Scandinavia. Through collaboration with world-leading suppliers, we provide our customers with the latest technology and innovative products.



CollyFLOWTECH

info@collyflowtech.se
Tel +46 8 703 01 30
www.collyflowtech.se

Sankt Eriksgatan 121A 113 43 Stockholm