

SERVICE & OPERATING MANUAL

ORIGINAL INSTRUCTIONS

E2

2" Elima-Matic Sanitary - ATEX

with Metal Center Section

E2 Metal Pumps

- Stainless Steel

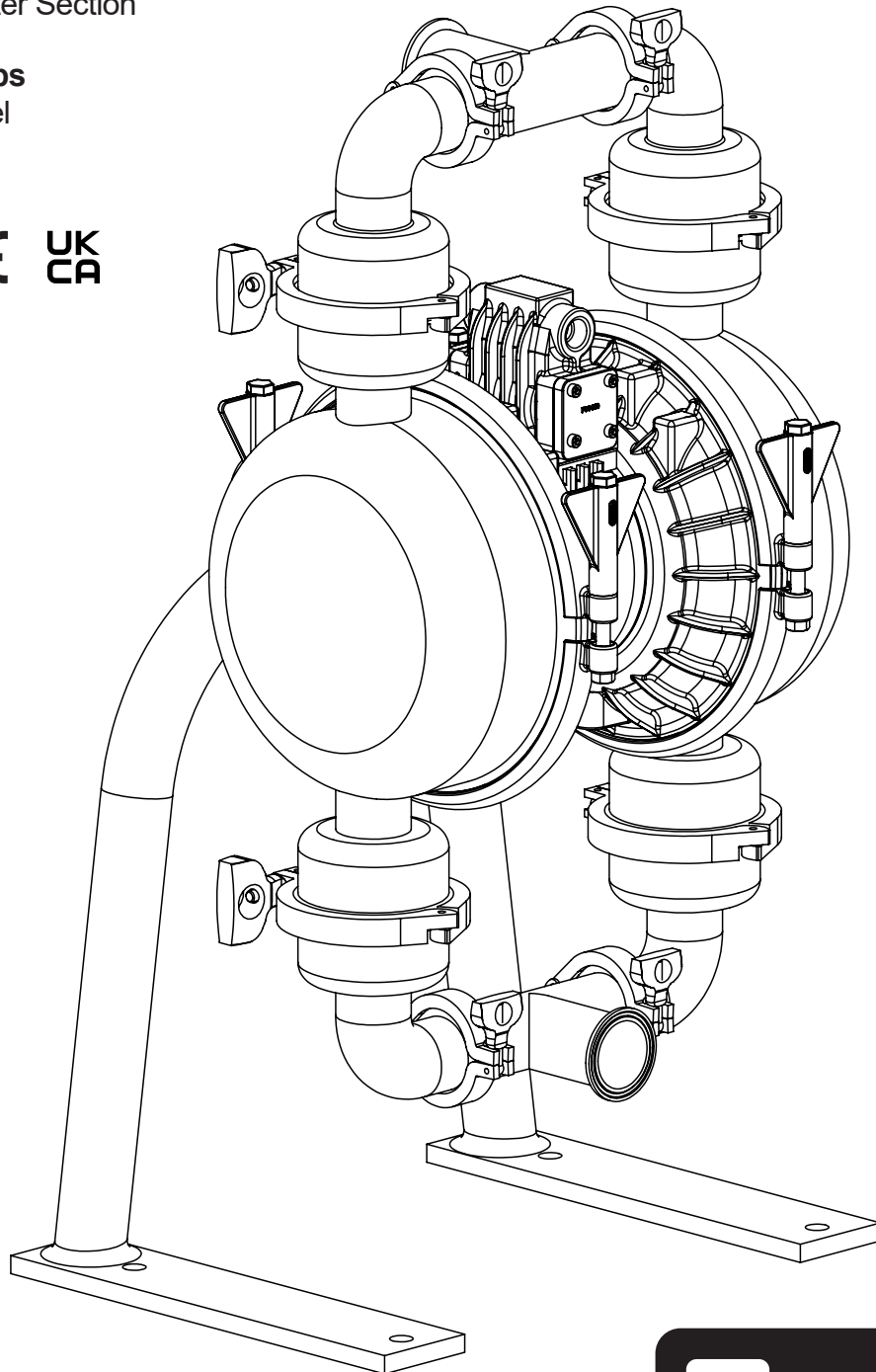

VERSAMATIC®

Safety Information

IMPORTANT



Read the safety warnings and instructions in this manual before pump installation and start-up. Failure to comply with the recommendations stated in this manual could damage the pump and void factory warranty.



When the pump is used for materials that tend to settle out or solidify, the pump should be flushed after each use to prevent damage. In freezing temperatures the pump should be completely drained between uses.

CAUTION



Before pump operation, inspect all fasteners for loosening caused by gasket creep. Retighten loose fasteners to prevent leakage. Follow recommended torques stated in this manual.



Plastic pumps and plastic components are not UV stabilized. Ultraviolet radiation can damage these parts and negatively affect material properties. Do not expose to UV light for extended periods of time.



WARNING

Pump not designed, tested or certified to be powered by compressed natural gas. Powering the pump with natural gas will void the warranty.



WARNING

The use of non-OEM replacement parts will void (or negate) agency certifications, including CE, ATEX, CSA, 3A and EC1935 compliance (Food Contact Materials). Warren Rupp, Inc. cannot ensure nor warrant non-OEM parts to meet the stringent requirements of the certifying agencies.

WARNING



When used for toxic or aggressive fluids, the pump should always be flushed clean prior to disassembly.



Before maintenance or repair, shut off the compressed air line, bleed the pressure, and disconnect the air line from the pump. Be certain that approved eye protection and protective clothing are worn at all times. Failure to follow these recommendations may result in serious injury or death.



Airborne particles and loud noise hazards. Wear eye and ear protection.



In the event of diaphragm rupture, pumped material may enter the air end of the pump, and be discharged into the atmosphere. If pumping a product that is hazardous or toxic, the air exhaust must be piped to an appropriate area for safe containment.



Take action to prevent static sparking. Fire or explosion can result, especially when handling flammable liquids. The pump, piping, valves, containers and other miscellaneous equipment must be properly grounded.



This pump is pressurized internally with air pressure during operation. Make certain that all fasteners and piping connections are in good condition and are reinstalled properly during reassembly.



Use safe practices when lifting

ATEX Pumps - Conditions For Safe Use

1. Ambient temperature range is as specified in tables 1 & 2 on the next page
2. ATEX compliant pumps are suitable for use in explosive atmospheres when the equipment is properly grounded in accordance with local electrical codes
3. Conductive Polypropylene, conductive Acetal or conductive PVDF pumps are not to be installed in applications where the pumps may be subjected to oil, greases and hydraulic liquids.
4. When operating pumps equipped with non-conductive diaphragms that exceed the maximum permissible projected area, as defined in EN ISO 80079-36 : 2016 section 6.7.5 table 8, the following protection methods must be applied
 - Equipment is always used to transfer electrically conductive fluids or
 - Explosive environment is prevented from entering the internal portions of the pump, i.e. dry running.

Temperature Tables

Table 1. Category 2 ATEX Rated Pumps

Ambient Temperature Range [°C]	Process Temperature Range [°C]	Temperature Class	Maximum Surface Temperature [°C]
-20°C to +60°C	-40°C to +80°C	T5	T100°C
	-40°C to +108°C	T4	T135°C
	-40°C to + 160°C	T3	T200°C
	-40°C to +177°C	(225°C) T2	

Table 2. Category M2 ATEX Rated Pumps for Mining

Ambient Temperature Range [°C]	Process Temperature Range [°C]
-20°C to +60°C	-40°C to +150°C

Note: The ambient temperature range and the process temperature range should not exceed the operating temperature range of the applied plastic parts as listed in the manuals of the pumps.

Table of Contents

SECTION 1: PUMP SPECIFICATIONS.....1

- Nomenclature
- Performance
- Materials
- Dimensional Drawings

SECTION 2: INSTALLATION & OPERATION ...8

- Principle of Pump Operation
- Typical Installation Guide
- Troubleshooting

SECTION 3: EXPLODED VIEW.....11

- Composite Drawings
- Parts List
- Materials Code

SECTION 4: WARRANTY & CERTIFICATES ..13

- Warranty
- EC Declaration of Conformity - Machinery
- EC Declaration of Conformity - ATEX
-  • EC Declaration of Conformity - EC Regulation 1935/2004/EC

1: PUMP SPECS

2: INSTAL & OP

3: EXP VIEW

4: AIR END

Explanation of Pump Nomenclature

Your Serial #: (fill in from pump nameplate) _____

Your Model #: _____
(fill in from pump nameplate)

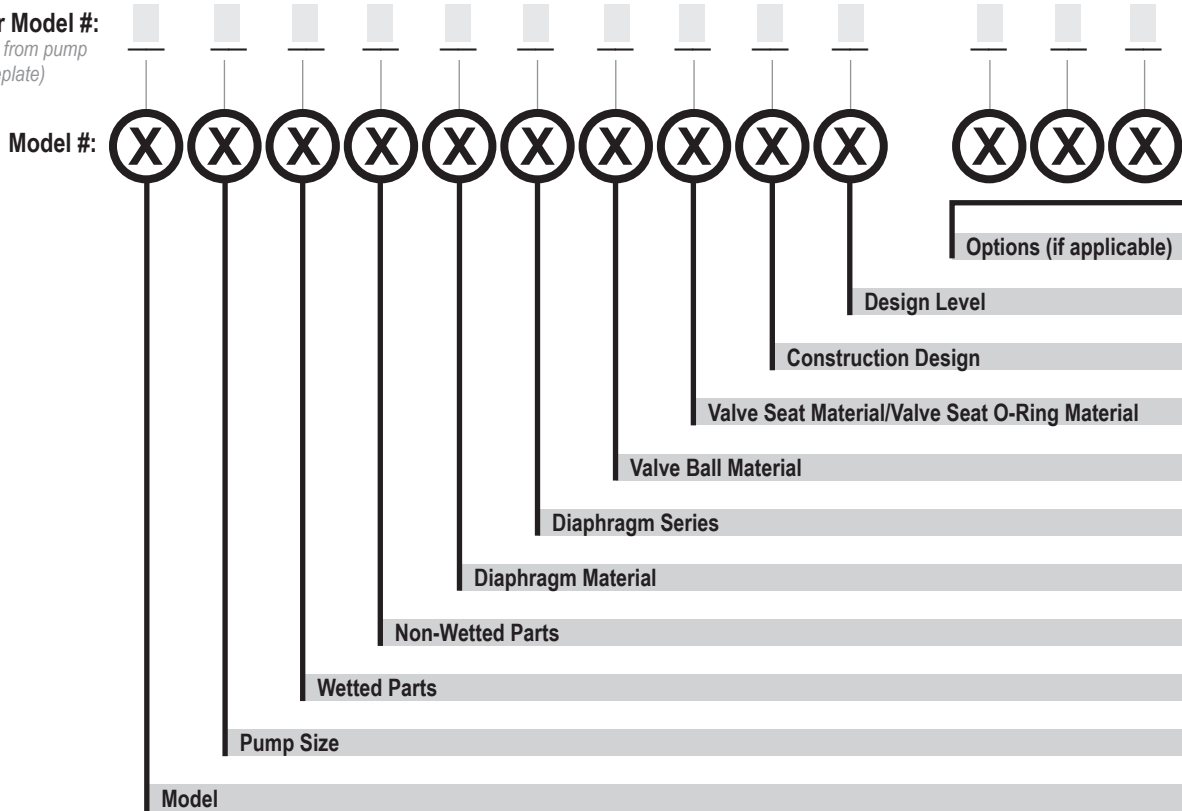

1: PUMP SPECS

Model	Pump Size	Wetted Parts	Non-Wetted Parts	Diaphragm Material
E Elima-Matic	6 1/4"	A Aluminum	A Aluminum	1 Neoprene
U Ultra-Matic	8 3/8"	C Cast Iron	S Stainless Steel	2 Nitrile (Nitrile)
V V-Series	5 1/2"	S Stainless Steel	P Polypropylene	3 FKM (Fluorocarbon)
	7 3/4"	H Alloy C	G Groundable Acetal	4 EPDM
	1 1"	P Polypropylene	Z PTFE-coated Aluminum	5 PTFE
	4 1-1/4" or 1-1/2"	K Kynar	J Nickel-plated Aluminum	6 Santoprene XL
	2 2"	G Groundable Acetal	C Cast Iron	7 Hytrel
	3 3"	B Aluminum (screen mount)	Q Epoxy-Coated Aluminum	Y FDA Santoprene

Diaphragm Series	Valve Ball Material Valve	Seat/Valve Seat O-Ring Material	Construction Design	Miscellaneous Options
R Rugged	1 Neoprene	1 Neoprene	9 Bolted	B BSP Tapered Thread
D Dome	2 Nitrile	2 Nitrile	0 Clamped	CP Center Port
X Thermo-Matic	3 (FKM) Fluorocarbon	3 (FKM) Fluorocarbon		ATEX ATEX Compliant
T Tef-Matic (2-piece)	4 EPDM	4 EPDM		FP Food Processing
B Versa-Tuff (1-piece)	5 PTFE	5 PTFE		SP Sanitary Pump
F FUSION (one-piece integrated plate)	6 Santoprene XL	6 Santoprene XL		HP High Pressure
	7 Hytrel	7 Hytrel		OE Original Elima-Matic
	8 Polyurethane	8 Polyurethane		F Flap Valve
	A Acetal	A Aluminum w/ PTFE O-Rings		HD Horizontal Discharge
	S Stainless Steel	S Stainless Steel w/ PTFE O-Rings		3A 3-A Certified
	Y FDA Santoprene	C Carbon Steel w/ PTFE O-Rings		UL UL Listed
		H Alloy C w/ PTFE O-Rings		OB Oil Bottle
		T PTFE Encapsulated Silicone O-Rings		
		Y FDA Santoprene		

*More than one option may be specified for a particular pump model.



Materials

1: PUMP SPECS

Material Profile:	Operating Temperatures:	
	Max.	Min.
CAUTION! Operating temperature limitations are as follows:		
Conductive Acetal: Tough, impact resistant, ductile. Good abrasion resistance and low friction surface. Generally inert, with good chemical resistance except for strong acids and oxidizing agents.	190°F 88°C	-20°F -29°C
EPDM: Shows very good water and chemical resistance. Has poor resistance to oils and solvents, but is fair in ketones and alcohols.	280°F 138°C	-40°F -40°C
FKM: (Fluorocarbon) Shows good resistance to a wide range of oils and solvents; especially all aliphatic, aromatic and halogenated hydrocarbons, acids, animal and vegetable oils. Hot water or hot aqueous solutions (over 70°F) will attack FKM.	350°F 177°C	-40°F -40°C
Hytrel®: Good on acids, bases, amines and glycols at room temperatures only.	220°F 104°C	-20°F -29°C
Neoprene: All purpose. Resistance to vegetable oils. Generally not affected by moderate chemicals, fats, greases and many oils and solvents. Generally attacked by strong oxidizing acids, ketones, esters and nitro hydrocarbons and chlorinated aromatic hydrocarbons.	200°F 93°C	-10°F -23°C
Nitrile: General purpose, oil-resistant. Shows good solvent, oil, water and hydraulic fluid resistance. Should not be used with highly polar solvents like acetone and MEK, ozone, chlorinated hydrocarbons and nitro hydrocarbons.	190°F 88°C	-10°F -23°C
Nylon: 6/6 High strength and toughness over a wide temperature range. Moderate to good resistance to fuels, oils and chemicals.	180°F 82°C	32°F 0°C

Polypropylene: A thermoplastic polymer. Moderate tensile and flex strength. Resists strong acids and alkali. Attacked by chlorine, fuming nitric acid and other strong oxidizing agents.	180°F 82°C	32°F 0°C
PVDF: (Polyvinylidene Fluoride) A durable fluoroplastic with excellent chemical resistance. Excellent for UV applications. High tensile strength and impact resistance.	250°F 121°C	0°F -18°C
Santoprene®: Injection molded thermoplastic elastomer with no fabric layer. Long mechanical flex life. Excellent abrasion resistance.	275°F 135°C	-40°F -40°C
UHMW PE: A thermoplastic that is highly resistant to a broad range of chemicals. Exhibits outstanding abrasion and impact resistance, along with environmental stress-cracking resistance.	180°F 82°C	-35°F -37°C
Urethane: Shows good resistance to abrasives. Has poor resistance to most solvents and oils.	150°F 66°C	32°F 0°C
Virgin PTFE: (PFA/TFE) Chemically inert, virtually impervious. Very few chemicals are known to chemically react with PTFE; molten alkali metals, turbulent liquid or gaseous fluorine and a few fluoro-chemicals such as chlorine trifluoride or oxygen difluoride which readily liberate free fluorine at elevated temperatures.	220°F 104°C	-35°F -37°C
<i>Maximum and Minimum Temperatures are the limits for which these materials can be operated. Temperatures coupled with pressure affect the longevity of diaphragm pump components. Maximum life should not be expected at the extreme limits of the temperature ranges.</i>		
Metals:		
Alloy C: Equal to ASTM494 CW-12M-1 specification for nickel and nickel alloy.		
Stainless Steel: Equal to or exceeding ASTM specification A743 CF-8M for corrosion resistant iron chromium, iron chromium nickel and nickel based alloy castings for general applications. Commonly referred to as 316 Stainless Steel in the pump industry.		

For specific applications, always consult the Chemical Resistance Chart.

Note: This document is a high level guide. Please be aware that not all model and or material combinations are possible for all sizes. Please consult factory or your distributor for specific details.

Performance

E2 - 2" Sanitary Pump – Metal Center TPE FITTED

Flow Rate

Adjustable to 0-179 gpm (677 lpm)

Port Size

Suction 2" TRI-CLAMP

Discharge 2" TRI-CLAMP

Air Inlet 1/2" NPT

Air Exhaust 1" NPT

Suction Lift

Dry 15' (4.6 m)

Wet 32' (9.8 m)

Max Solid Size (Diameter)

..... 5/8" (15.8 mm)

Max Noise Level 98 dB(A)

Shipping Weights

Stainless 134 lbs (60.8 kg)

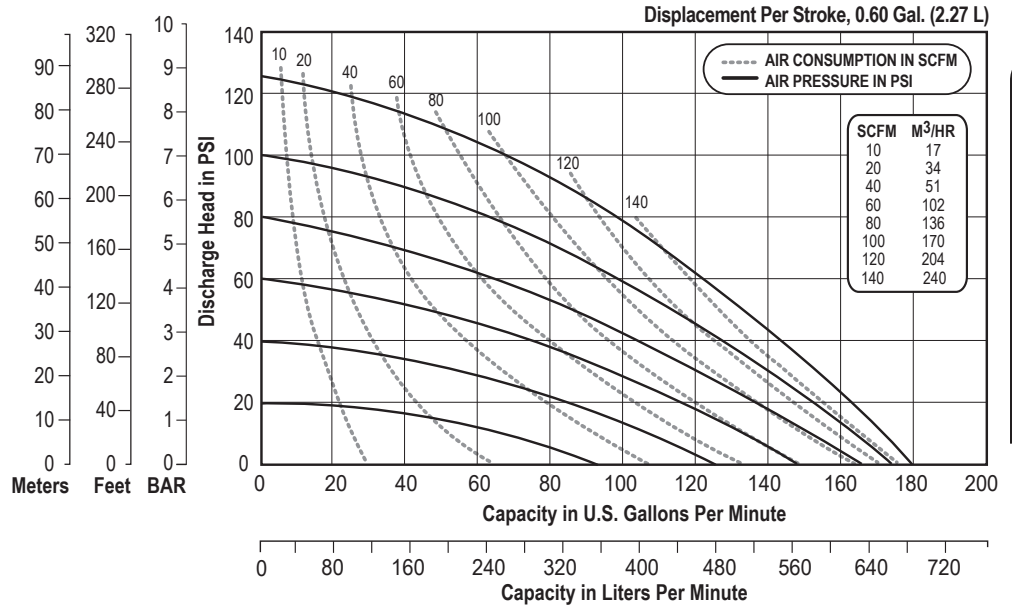

NOTE: Performance based on the following: TPE fitted pump, flooded suction, water at ambient conditions. The use of other materials and varying hydraulic conditions may result in deviations in excess of 5%.

E2 - 2" Sanitary Pump – Metal Center PTFE FITTED

Flow Rate

Adjustable to 0-147 gpm (556 lpm)

Port Size

Suction 2" TRI-CLAMP

Discharge 2" TRI-CLAMP

Air Inlet 1/2" NPT

Air Exhaust 1" NPT

Suction Lift

Dry 9' (2.7 m)

Wet 27' (8.2 m)

Max Solid Size (Diameter)

..... 5/8" (15.8 mm)

Max Noise Level 98 dB(A)

Shipping Weights

Stainless 134 lbs (60.8 kg)

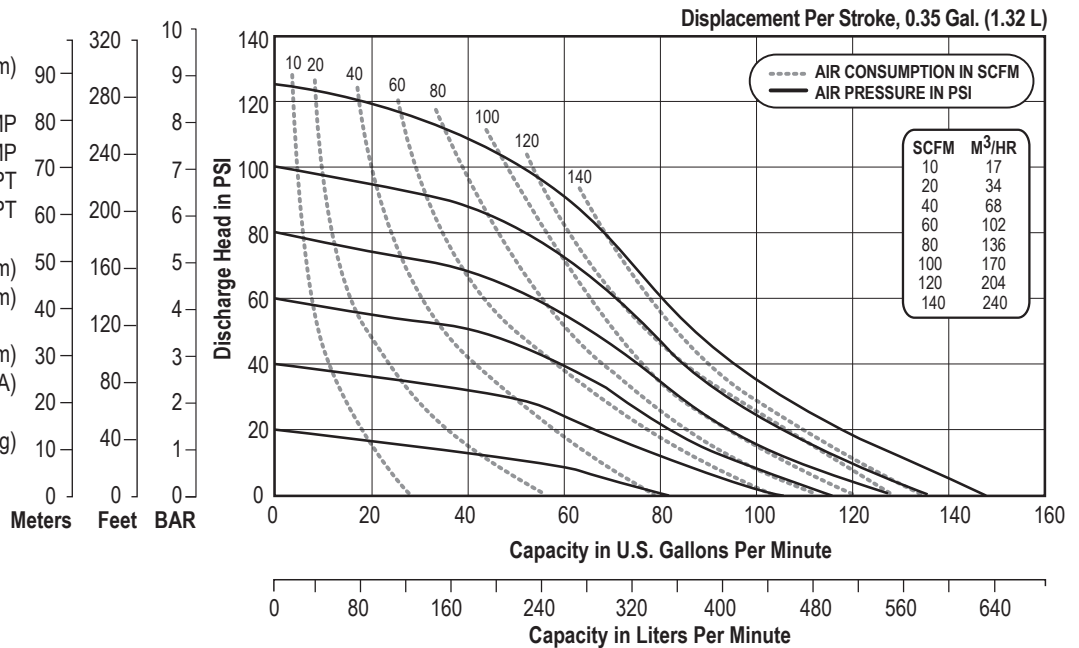

NOTE: Performance based on the following: PTFE fitted pump, flooded suction, water at ambient conditions. The use of other materials and varying hydraulic conditions may result in deviations in excess of 5%.

Dimensional Drawings

E2 Sanitary

Dimensions in inches (mm dimensions in brackets)

The dimensions on this drawing are for reference only. A certified drawing can be requested if physical dimensions are needed.

1: PUMP SPECS

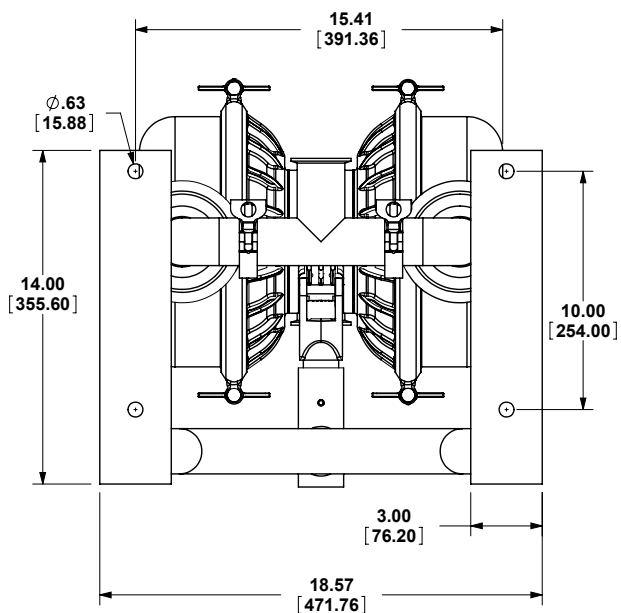
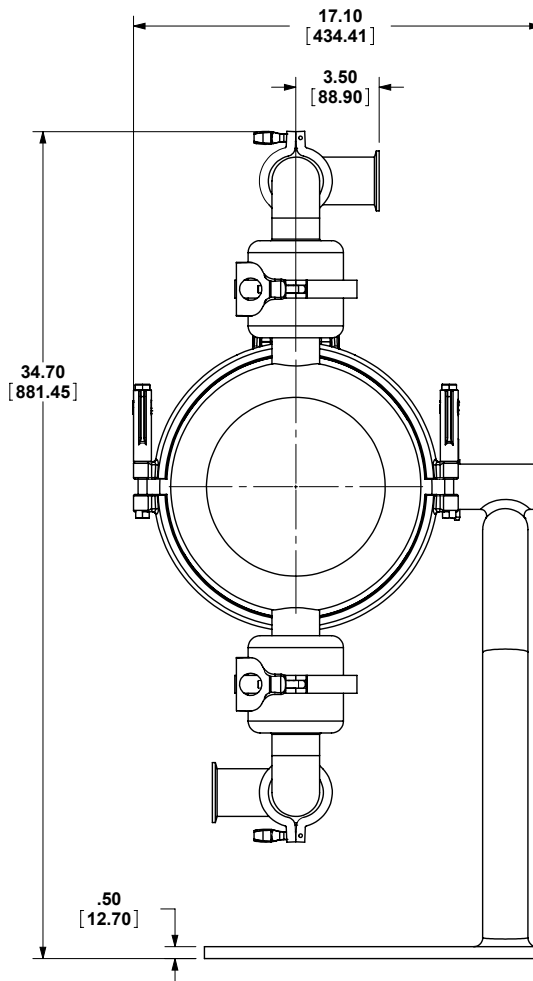
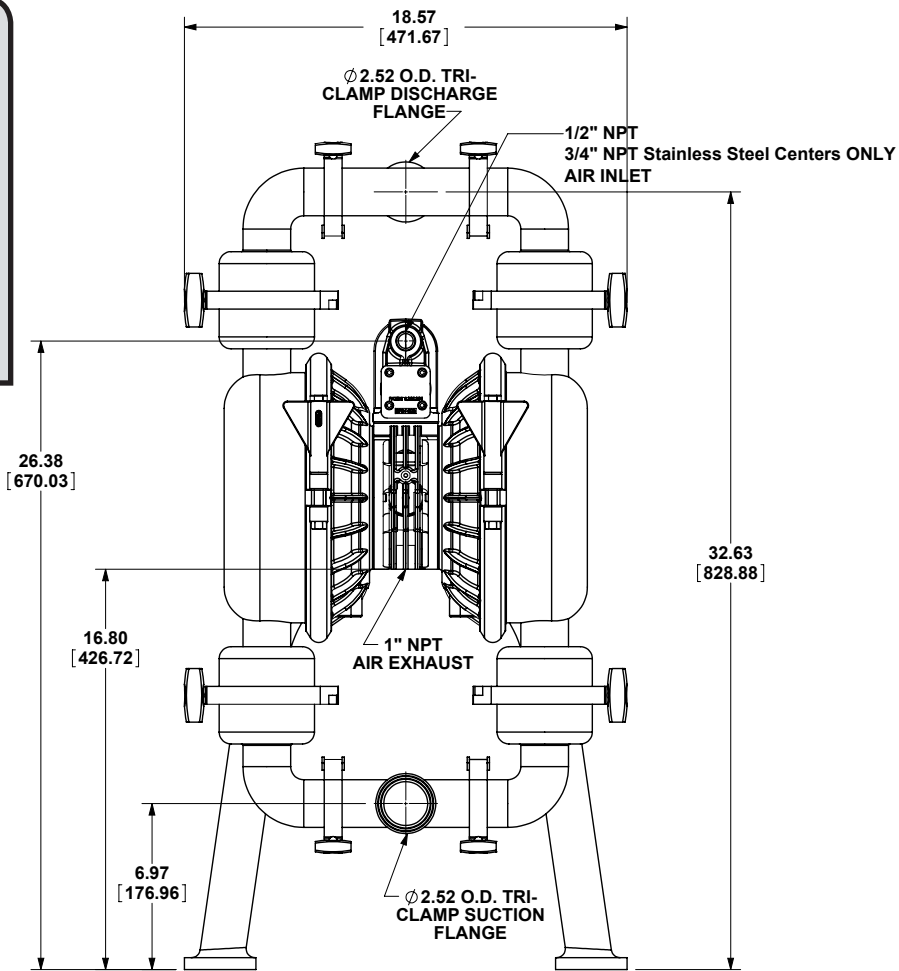

Principle of Pump Operation

Air-Operated Double Diaphragm (AODD) pumps are powered by compressed air or nitrogen.

The main directional (air) control valve ① distributes compressed air to an air chamber, exerting uniform pressure over the inner surface of the diaphragm ②. At the same time, the exhausting air ③ from behind the opposite diaphragm is directed through the air valve assembly(s) to an exhaust port ④.

As inner chamber pressure (P1) exceeds liquid chamber pressure (P2), the rod ⑤ connected diaphragms shift together creating discharge on one side and suction on the opposite side. The discharged and primed liquid's directions are controlled by the check valves (ball or flap) ⑥ orientation.

The pump primes as a result of the suction stroke. The suction stroke lowers the chamber pressure (P3) increasing the chamber volume. This results in a pressure differential necessary for atmospheric pressure (P4) to push the fluid through the suction piping and across the suction side check valve and into the outer fluid chamber ⑦.

Suction (side) stroking also initiates the reciprocating (shifting, stroking or cycling) action of the pump. The suction diaphragm's movement is mechanically pulled through its stroke. The diaphragm's inner plate makes contact with an actuator plunger aligned to shift the pilot signaling valve. Once actuated, the pilot valve sends a pressure signal to the opposite end of the main directional air valve, redirecting the compressed air to the opposite inner chamber.

SUBMERGED ILLUSTRATION

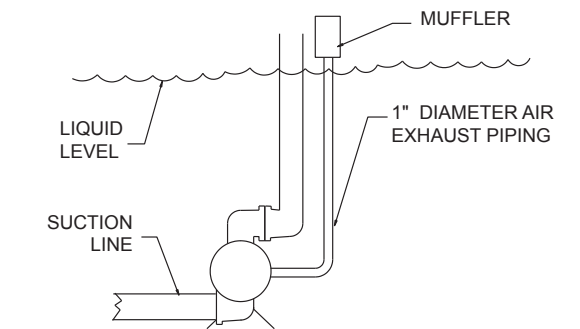

Pump can be submerged if the pump materials of construction are compatible with the liquid being pumped. The air exhaust must be piped above the liquid level. When the pumped product source is at a higher level than the pump (flooded suction condition), pipe the exhaust higher than the product source to prevent siphoning spills.

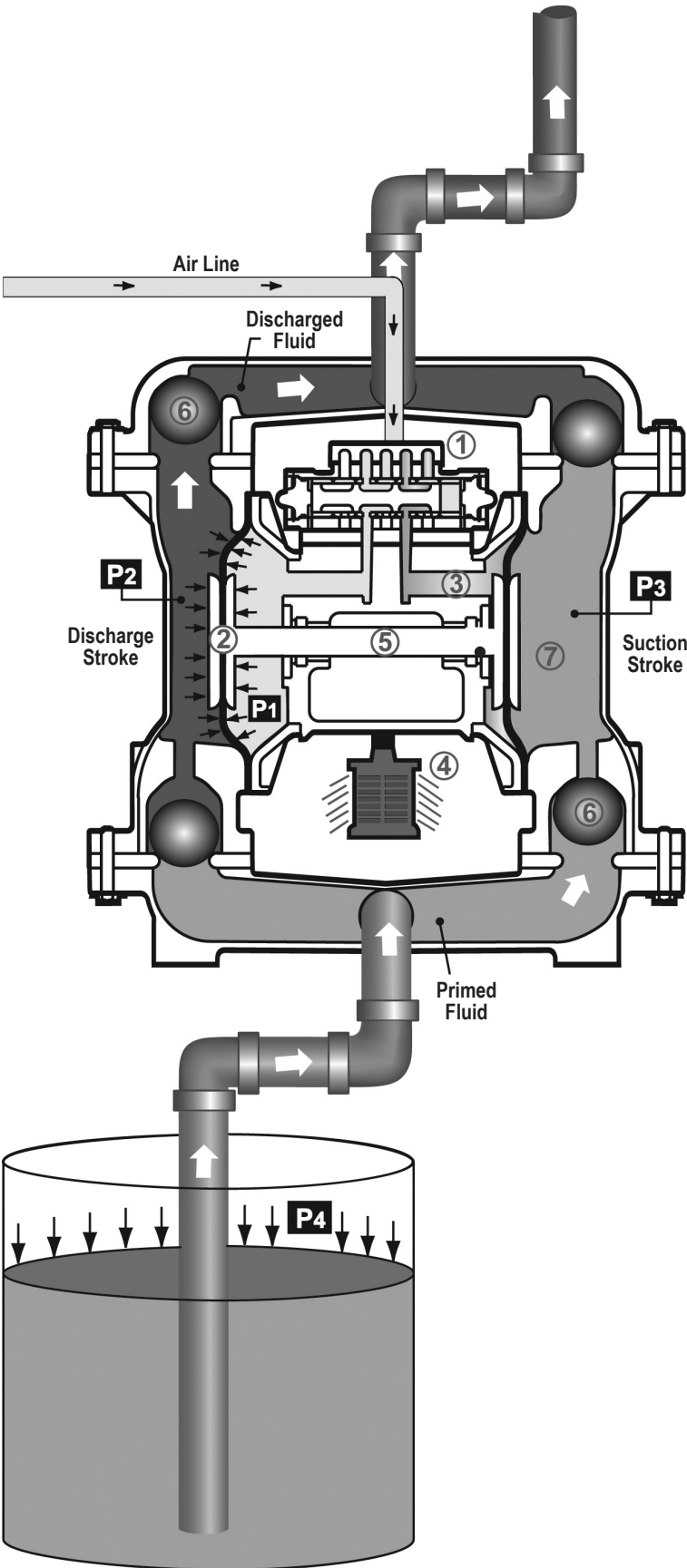

2: INSTAL & OP

Recommended Installation Guide

Available Accessories:

1. Surge Suppressor
2. Filter/Regulator
3. Air Dryer
4. Lubricator

Note: Surge Suppressor and Piping, including air line, must be supported after the flexible connections.

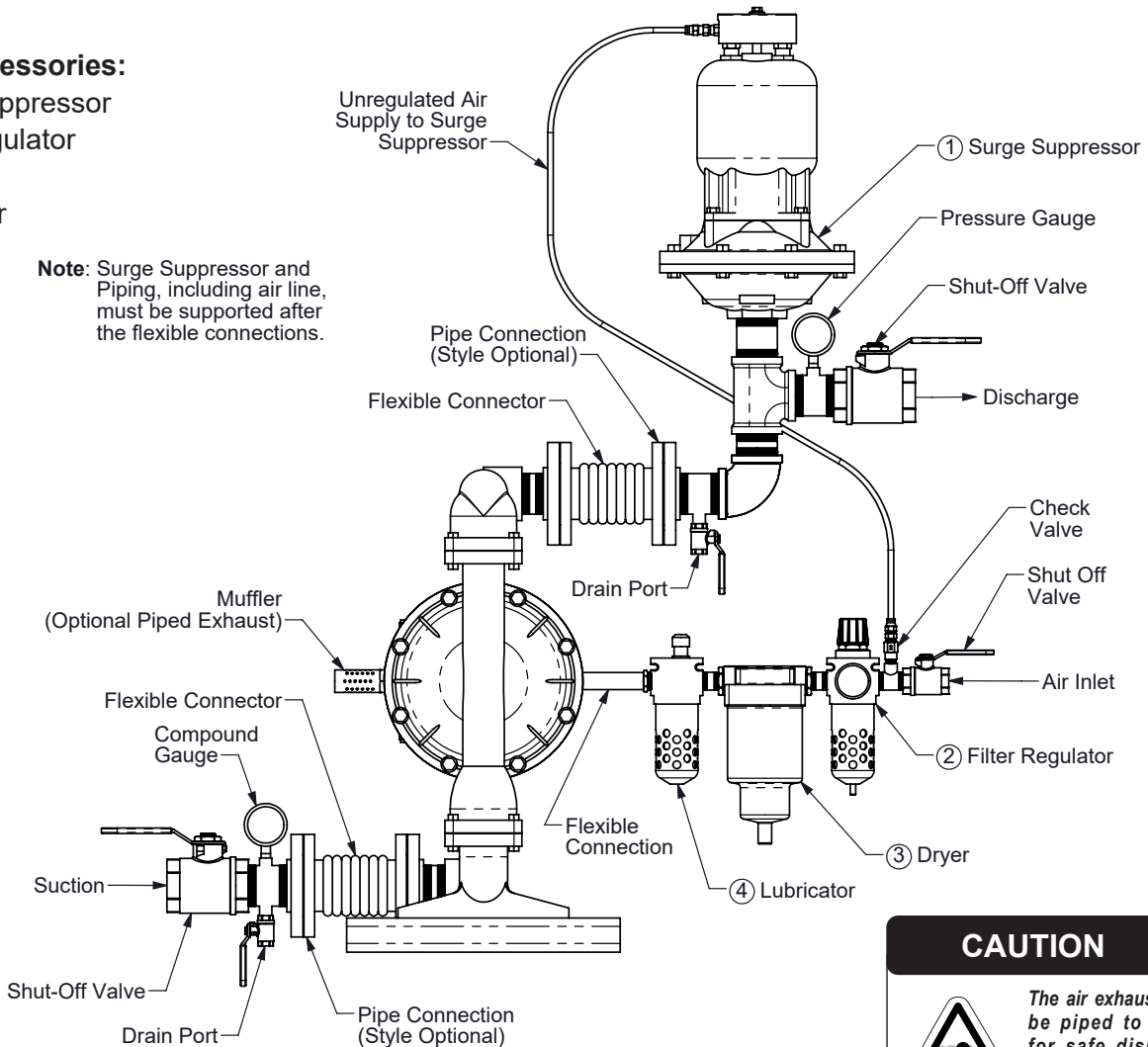

CAUTION



The air exhaust should be piped to an area for safe disposition of the product being pumped, in the event of a diaphragm failure.

Installation And Start-Up

Locate the pump as close to the product being pumped as possible. Keep the suction line length and number of fittings to a minimum. Do not reduce the suction line diameter.

Air Supply

Connect the pump air inlet to an air supply with sufficient capacity and pressure to achieve desired performance. A pressure regulating valve should be installed to insure air supply pressure does not exceed recommended limits.

Air Valve Lubrication

The air distribution system is designed to operate **WITHOUT** lubrication. This is the standard mode of operation. If lubrication is desired, install an air line lubricator set to deliver one drop of SAE 10 non-detergent oil for every 20 SCFM (9.4 liters/sec.) of air the pump consumes. Consult the Performance Curve to determine air consumption.

Air Line Moisture

Water in the compressed air supply may cause icing or freezing of the exhaust air, causing the pump to cycle erratically or stop operating. Water in the air supply can be reduced by using a point-of-use air dryer.

Air Inlet And Priming

To start the pump, slightly open the air shut-off valve. After the pump primes, the air valve can be opened to increase air flow as desired. If opening the valve increases cycling rate, but does not increase the rate of flow, cavitation has occurred. The valve should be closed slightly to obtain the most efficient air flow to pump flow ratio.

Troubleshooting Guide

Symptom:	Potential Cause(s):	Recommendation(s):
Pump Cycles Once	Deadhead (system pressure meets or exceeds air supply pressure).	Increase the inlet air pressure to the pump. Pump is designed for 1:1 pressure ratio at zero flow. (Does not apply to high pressure 2:1 units).
	Air valve or intermediate gaskets installed incorrectly.	Install gaskets with holes properly aligned.
	Bent or missing actuator plunger.	Remove pilot valve and inspect actuator plungers.
Pump Will Not Operate / Cycle	Pump is over lubricated.	Set lubricator on lowest possible setting or remove. Units are designed for lube free operation.
	Lack of air (line size, PSI, CFM).	Check the air line size and length, compressor capacity (HP vs. cfm required).
	Check air distribution system.	Disassemble and inspect main air distribution valve, pilot valve and pilot valve actuators.
	Discharge line is blocked or clogged manifolds.	Check for inadvertently closed discharge line valves. Clean discharge manifolds/piping.
	Deadhead (system pressure meets or exceeds air supply pressure).	Increase the inlet air pressure to the pump. Pump is designed for 1:1 pressure ratio at zero flow. (Does not apply to high pressure 2:1 units).
	Blocked air exhaust muffler.	Remove muffler screen, clean or de-ice, and re-install.
	Pumped fluid in air exhaust muffler.	Disassemble pump chambers. Inspect for diaphragm rupture or loose diaphragm plate assembly.
	Pump chamber is blocked.	Disassemble and inspect wetted chambers. Remove or flush any obstructions.
Pump Cycles and Will Not Prime or No Flow	Cavitation on suction side.	Check suction condition (move pump closer to product).
	Check valve obstructed. Valve ball(s) not seating properly or sticking.	Disassemble the wet end of the pump and manually dislodge obstruction in the check valve pocket. Clean out around valve ball cage and valve seat area. Replace valve ball or valve seat if damaged. Use heavier valve ball material.
	Valve ball(s) missing (pushed into chamber or manifold).	Worn valve ball or valve seat. Worn fingers in valve ball cage (replace part). Check Chemical Resistance Guide for compatibility.
	Valve ball(s)/seat(s) damaged or attacked by product.	Check Chemical Resistance Guide for compatibility.
	Check valve and/or seat is worn or needs adjusting.	Inspect check valves and seats for wear and proper setting. Replace if necessary.
	Suction line is blocked.	Remove or flush obstruction. Check and clear all suction screens or strainers.
	Excessive suction lift.	For lifts exceeding 20' of liquid, filling the chambers with liquid will prime the pump in most cases.
	Suction side air leakage or air in product.	Visually inspect all suction-side gaskets and pipe connections.
	Pumped fluid in air exhaust muffler.	Disassemble pump chambers. Inspect for diaphragm rupture or loose diaphragm plate assembly.
Pump Cycles Running Sluggish/Stalling, Flow Unsatisfactory	Over lubrication.	Set lubricator on lowest possible setting or remove. Units are designed for lube free operation.
	Icing.	Remove muffler screen, de-ice, and re-install. Install a point of use air drier.
	Clogged manifolds.	Clean manifolds to allow proper air flow
	Deadhead (system pressure meets or exceeds air supply pressure).	Increase the inlet air pressure to the pump. Pump is designed for 1:1 pressure ratio at zero flow. (Does not apply to high pressure 2:1 units).
	Cavitation on suction side.	Check suction (move pump closer to product).
	Lack of air (line size, PSI, CFM).	Check the air line size, length, compressor capacity.
	Excessive suction lift.	For lifts exceeding 20' of liquid, filling the chambers with liquid will prime the pump in most cases.
	Air supply pressure or volume exceeds system hd.	Decrease inlet air (press. and vol.) to the pump. Pump is cavitating the fluid by fast cycling.
	Undersized suction line.	Meet or exceed pump connections.
	Restrictive or undersized air line.	Install a larger air line and connection.
	Suction side air leakage or air in product.	Visually inspect all suction-side gaskets and pipe connections.
	Suction line is blocked.	Remove or flush obstruction. Check and clear all suction screens or strainers.
	Pumped fluid in air exhaust muffler.	Disassemble pump chambers. Inspect for diaphragm rupture or loose diaphragm plate assembly.
	Check valve obstructed.	Disassemble the wet end of the pump and manually dislodge obstruction in the check valve pocket.
	Check valve and/or seat is worn or needs adjusting.	Inspect check valves and seats for wear and proper setting. Replace if necessary.
Entrained air or vapor lock in chamber(s).	Purge chambers through tapped chamber vent plugs. Purging the chambers of air can be dangerous.	
Product Leaking Through Exhaust	Diaphragm failure, or diaphragm plates loose.	Replace diaphragms, check for damage and ensure diaphragm plates are tight.
	Diaphragm stretched around center hole or bolt holes.	Check for excessive inlet pressure or air pressure. Consult Chemical Resistance Chart for compatibility with products, cleaners, temperature limitations and lubrication.
Premature Diaphragm Failure	Cavitation.	Enlarge pipe diameter on suction side of pump.
	Excessive flooded suction pressure.	Move pump closer to product. Raise pump/place pump on top of tank to reduce inlet pressure. Install Back pressure device (Tech bulletin 41r). Add accumulation tank or pulsation dampener.
	Misapplication (chemical/physical incompatibility).	Consult Chemical Resistance Chart for compatibility with products, cleaners, temperature limitations and lubrication.
	Incorrect diaphragm plates or plates on backwards, installed incorrectly or worn.	Check Operating Manual to check for correct part and installation. Ensure outer plates have not been worn to a sharp edge.
Unbalanced Cycling	Excessive suction lift.	For lifts exceeding 20' of liquid, filling the chambers with liquid will prime the pump in most cases.
	Undersized suction line.	Meet or exceed pump connections.
	Pumped fluid in air exhaust muffler.	Disassemble pump chambers. Inspect for diaphragm rupture or loose diaphragm plate assembly.
	Suction side air leakage or air in product.	Visually inspect all suction-side gaskets and pipe connections.
	Check valve obstructed.	Disassemble the wet end of the pump and manually dislodge obstruction in the check valve pocket.
	Check valve and/or seat is worn or needs adjusting.	Inspect check valves and seats for wear and proper setting. Replace if necessary.
Entrained air or vapor lock in chamber(s).	Purge chambers through tapped chamber vent plugs.	

2: INSTAL & OP

For additional troubleshooting tips contact After Sales Support at service.warrenrupp@idexcorp.com or 419-524-8388

Pump Inspection and Cleaning

The Elima-Matic sanitary pump can be cleaned using several techniques. However, it is important to follow guidelines set by the IAMFES, the USPHS, and the DIC and/or internal rules for inspection, cleaning and sanitization. Remove the valve balls and ball cages from the pump and clean components separate from the pump.

If the pump is to be steam cleaned, disconnect the suction line from the pump. Connect the steam line to the pump inlet. Maintain the flow of steam through the pump for at least five minutes after the temperature at the outlet has reached 200°F (94°C).

Hot water may also be used. Pump water that is maintained at minimum of 170°F (77°C) through the pump for at least five minutes. Please note that the maximum cleaning temperature of the pump is 220° (104°C).

Chemical cleaning may also be used in sanitizing the pump. Be sure to consult your distributor or the manufacturer to verify that the elastomer(s) used in the pump are compatible with the chemicals being used in the cleaning process.

Composite Repair Parts Drawing

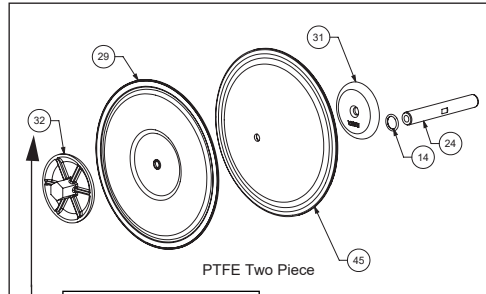
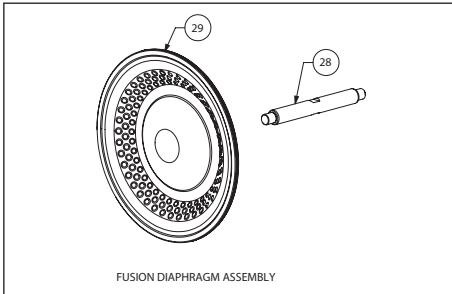

Torque Setting:
960 in-lbs.
(180 N-m)

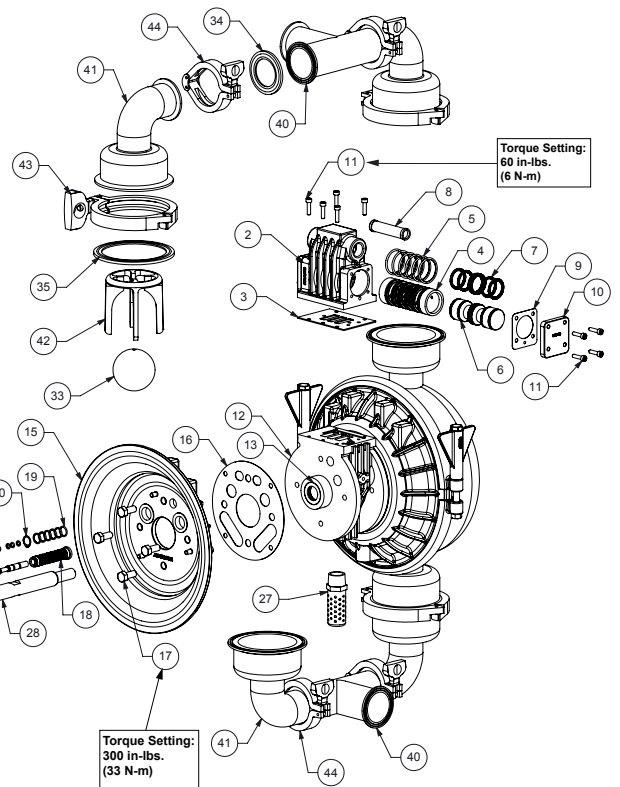
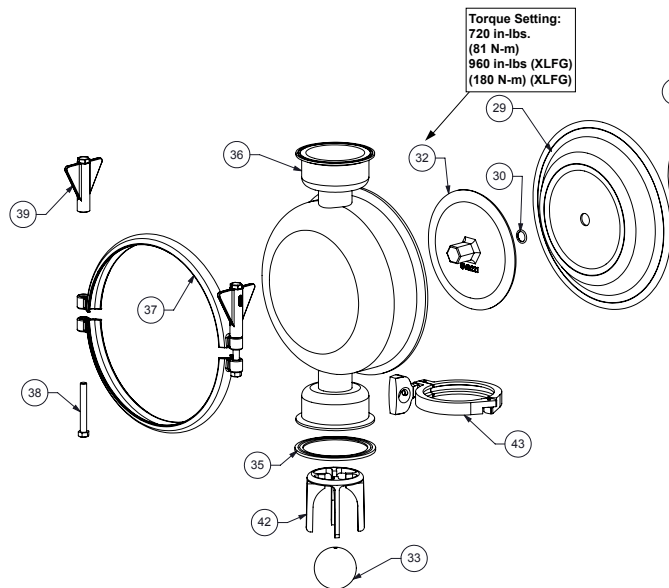
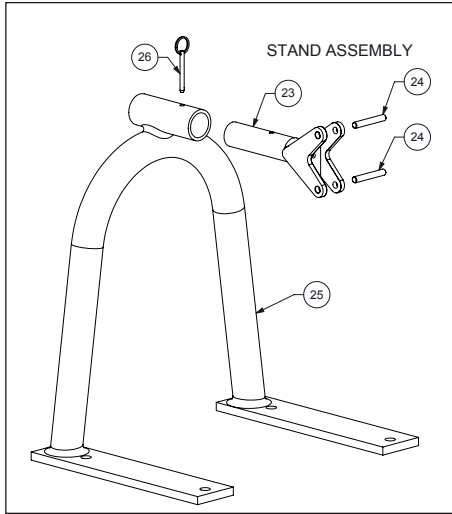

3: EXP VIEW

Composite Repair Parts List

Air Valve Assembly						
Item #	Qty.	Description	Part Number			
			Stainless Steel		Nickle Plated	
		Air Side Repair Kit (Includes Items 3,5,7,9,14,16,18-22)	476.V019.000			
1	1	Valve Body (includes items 2-11)	031.V002.114		031.V002.332	
2	1	Valve Body	095.V001.114		095.V001.332	
3	1	Valve Body Gasket	P24-202			
4	1	Valve Sleeve	755.V006.148			
5	6	O-ring	560.206.360			
6	1	Valve Spool Assembly (Includes items 7)	775.V001.000			
7	6	Glyde Ring Assembly	P34-204F			
8	1	Air Valve Screen	P34-210		P24-210	
9	2	End Cap Gasket	P24-205			
10	2	End Cap	SP34-300			
11	13	Mounting Screws (8 included on item 1)	S1001			
Center Section Assembly						
Item #	Qty.	Description	Part Number			
			Stainless Steel		Nickle Plated	
12	1	Center Block Assembly (Includes item 13 & 14)	SP24-400 3A		P24-4003ANP ASY	
13	2	Bearing Sleeve	P31-403			
14	2	Main Shaft O-Ring	P24-403			
15	2	Air Chamber	196.V002.110			
16	2	Air Chamber Gasket	360.V001.360			
17	8	Bolt	SP24-110			
		Pilot Repair Kit (Includes Items 18-22)	476.V018.000			
18	1	Pilot Sleeve Assembly (include item 19)	755.V002.000			
19	6	O-ring	560.101.358			
20	1	Retaining Ring	675.037.080			
21	1	Pilot Spool Assembly (Includes item 22)	775.V002.000			
22	8	O-ring	560.023.358			
23	1	Stand Attachment	SP31-651			
24	2	Stand Attachment Pin	P29-654			
25	1	Stand	SP29-650CP			
26	1	Stand Locking Pin	P29-652			
27	1	Muffler	530.058.000			
Diaphragm Assembly / Elastomers						
Item #	Qty.	Description	Part Number		PTFE	
			FDA Santoprene	FDA Hytel	Two Piece	Fusion
28	1	Main Shaft	P31-103	P31-103	P31-102	P24-103F
29	2	Diaphragm	V241TPEXLFG	V224TPEFG	V224TF	V224F
45	2	Back-Up Diaphragm	N/A	N/A	V224TFB	N/A
30	2	O-ring	V221D	V221D	N/A	N/A
31	2	Inner Diaphragm Plate (See Note 1 Below)	V221BNP, SV221B	V221BNP	V221TINP or SV221TI	N/A
32	2	Outer Diaphragm Plate	SVB221-3A	SVB221-3A	SV221TOFG	N/A
33	4	Valve Ball (See Material Chart Below)	V241TPEFG, V241TF	V241TPEFG	V241 TF	V241TF
34	4	Manifold Tee Seal	V275E	V275TF	V275TF	V275TF
35	4	Manifold Elbow Seal	V276E	V276TF	V276TF	V276TF
Wet End Assembly						
Item #	Qty.	Description	Part Number			
36	2	Water Chamber	D29-235			
37	4	Large Clamp Half	SV230A			
38	4	Bolt	SV230C			
39	4	Wing Nut	FG30D			
40	2	Manifold Tee	D29-238			
41	4	Manifold Elbow	D29-237			
42	4	Ball Cage	670.V003.110			
43	4	Manifold Elbow Clamp	V275A			
44	4	Manifold Tee Clamp	V276A			

Notes:

- 1.) The inner diaphragm plate material is to match the air chamber material (Ref. Note 3)
SV=Stainless Steel, NP=Nickle Plated

3: EXP VIEW

Material Codes - The Last 3 Digits of Part Number

000.....Assembly, sub-assembly; and some purchased items	364.....EPDM Rubber Color coded: BLUE
010.....Cast Iron	365.....Neoprene Rubber Color coded: GREEN
015.....Ductile Iron	366.....Food Grade Nitrile
020.....Ferritic Malleable Iron	368.....Food Grade EPDM
080.....Carbon Steel, AISI B-1112	371.....Philthane (Tuftane)
110.....Alloy Type 316 Stainless Steel	374.....Carboxylated Nitrile
111.....Alloy Type 316 Stainless Steel (Electro Polished)	375.....Fluorinated Nitrile
112.....Alloy C	378.....High Density Polypropylene
113.....Alloy Type 316 Stainless Steel (Hand Polished)	379.....Conductive Nitrile
114.....303 Stainless Steel	408.....Cork and Neoprene
115.....302/304 Stainless Steel	425.....Compressed Fibre
117.....440-C Stainless Steel (Martensitic)	426.....Blue Gard
120.....416 Stainless Steel (Wrought Martensitic)	440.....Vegetable Fibre
148.....Hardcoat Anodized Aluminum	500.....Delrin® 500
150.....6061-T6 Aluminum	502.....Conductive Acetal, ESD-800
152.....2024-T4 Aluminum (2023-T351)	503.....Conductive Acetal, Glass-Filled
155.....356-T6 Aluminum	506.....Delrin® 150
156.....356-T6 Aluminum	520.....Injection Molded PVDF Natural color
157.....Die Cast Aluminum Alloy #380	540.....Nylon
158.....Aluminum Alloy SR-319	542.....Nylon
162.....Brass, Yellow, Screw Machine Stock	544.....Nylon Injection Molded
165.....Cast Bronze, 85-5-5-5	550.....Polyethylene
166.....Bronze, SAE 660	551.....Glass Filled Polypropylene
170.....Bronze, Bearing Type, Oil Impregnated	552.....Unfilled Polypropylene
180.....Copper Alloy	555.....Polyvinyl Chloride
305.....Carbon Steel, Black Epoxy Coated	556.....Black Vinyl
306.....Carbon Steel, Black PTFE Coated	558.....Conductive HDPE
307.....Aluminum, Black Epoxy Coated	570.....Rulon II®
308.....Stainless Steel, Black PTFE Coated	580.....Ryton®
309.....Aluminum, Black PTFE Coated	600.....PTFE (virgin material) Tetrafluorocarbon (TFE)
313.....Aluminum, White Epoxy Coated	603.....Blue Gylon®
330.....Zinc Plated Steel	604.....PTFE
332.....Aluminum, Electroless Nickel Plated	606.....PTFE
333.....Carbon Steel, Electroless Nickel Plated	607.....Envelon
335.....Galvanized Steel	608.....Conductive PTFE
337.....Silver Plated Steel	610.....PTFE Encapsulated Silicon
351.....Food Grade Santoprene®	611.....PTFE Encapsulated FKM
353.....Geolast; Color: Black	632.....Neoprene/Hytrel®
354.....Injection Molded #203-40 Santoprene® Duro 40D +/-5; Color: RED	633.....FKM/PTFE
356.....Hytrel®	634.....EPDM/PTFE
357.....Injection Molded Polyurethane	635.....Neoprene/PTFE
358.....Urethane Rubber (Some Applications) (Compression Mold)	637.....PTFE, FKM/PTFE
359.....Urethane Rubber	638.....PTFE, Hytrel®/PTFE
360.....Nitrile Rubber Color coded: RED	639.....Nitrile/TFE
363.....FKM (Fluorocarbon) Color coded: YELLOW	643.....Santoprene®/EPDM
	644.....Santoprene®/PTFE
	656.....Santoprene® Diaphragm and Check Balls/EPDM Seats
	661.....EPDM/Santoprene®
	666.....FDA Nitrile Diaphragm, PTFE Overlay, Balls, and Seals
	668.....PTFE, FDA Santoprene®/PTFE

- Delrin and Hytrel are registered tradenames of E.I. DuPont.
- Nylatron is a registered tradename of Polymer Corp.
- Gylon is a registered tradename of Garlock, Inc.
- Santoprene is a registered tradename of Exxon Mobil Corp.
- Rulon II is a registered tradename of Dixon Industries Corp.
- Ryton is a registered tradename of Phillips Chemical Co.
- Valox is a registered tradename of General Electric Co.

RECYCLING

Warren Rupp, manufacturer of Versamatic, is an ISO14001 registered company and is committed to minimizing the impact our products have on the environment. Many components of Versamatic® AODD pumps are made of recyclable materials. We encourage pump users to recycle worn out parts and pumps whenever possible, after any hazardous pumped fluids are thoroughly flushed. Pump users that recycle will gain the satisfaction to know that their discarded part(s) or pump will not end up in a landfill. The recyclability of Versamatic products is a vital part of Warren Rupp's commitment to environmental stewardship.

5 - YEAR Limited Product Warranty

Quality System ISO9001 Certified • Environmental Management Systems ISO14001 Certified

Versamatic warrants to the original end-use purchaser that no product sold by Versamatic that bears a Versamatic brand shall fail under normal use and service due to a defect in material or workmanship within five years from the date of shipment from Versamatic's factory.

The use of non-OEM replacement parts will void (or negate) agency certifications, including CE, ATEX, CSA, 3A and EC1935 compliance (Food Contact Materials). Warren Rupp, Inc. cannot ensure nor warrant non-OEM parts to meet the stringent requirements of the certifying agencies.

~ See complete warranty at <https://www.versamatic.com/>



EC Declaration of Conformity

Manufacturer:
Warren Rupp, Inc.
800 N. Main Street
Mansfield, Ohio, 44902 USA

Certifies that Air-Operated Double Diaphragm Pump Models: E Series, VL Series, VM Series, U2 Series; Submersible Pump Models: VSMA3 Series, SPA15 Series and Surge Dampener/Suppressor Models: VDA Series, VTA Series comply with the European Community Directive 2006/42/EC on Machinery, according to Annex VIII. This product has used Harmonized Standard EN809:2012, Pumps and Pump Units for Liquids - Common Safety Requirements, to verify conformance.

October 3, 2022

DATE/APPROVAL/TITLE:

Technical File on record with:
DEKRA Certification B.V.
Meander 1051
6825 MJ Arnhem
The Netherlands



Signature of authorized person

Dennis Hall

Printed name of authorized person

Engineering Manager

Title





EC Declaration of Conformity

Manufacturer:
Warren Rupp, Inc.
800 N. Main Street
Mansfield, Ohio, 44902 USA

Certifies that Air-Operated Double Diaphragm Pump Models: E Series, VL Series, VM Series, U2 Series; Submersible Pump Models: VSMA3 Series, SPA15 Series and Surge Dampener/Suppressor Models: VDA Series, VTA Series comply with the United Kingdom Statutory Instruments 2008 No. 1597, The Supply of Machinery (Safety) Regulations 2008, according to Annex VIII. This product has used Designated Standard EN809:2012, Pumps and Pump Units for Liquids - Common Safety Requirements, to verify conformance.

October 17, 2022
DATE/APPROVAL/TITLE:

Technical File on record with:
DEKRA Certification UK Limited
Stokenchurch House
Oxford Road
Stokenchurch
HP14 3SX

Signature of authorized person

Dennis Hall
Printed name of authorized person

Engineering Manager
Title





VERSAMATIC®

ATEX



EU Declaration of Conformity

Manufacturer:

Warren Rupp, Inc.
A Unit of IDEX Corporation
800 North Main Street
Mansfield, OH 44902 USA

This declaration of conformity is issued under the sole responsibility of the manufacturer. Warren Rupp, Inc. declares that Air Operated Double Diaphragm Pumps (AODD) and Surge Suppressors listed below comply with the requirements of Directive **2014/34/EU** and applicable harmonized standards.

Harmonized Standards:

- EN ISO 80079-36: 2016
- EN ISO 80079-37: 2016

1. AODD Pumps and Surge Suppressors - Technical File on record with: DEKRA Certification B.V.
Meander 1051
6825 MJ Arnhem
The Netherlands

Hazardous Location Applied:

-  II 2 G Ex h IIC T5...225°C (T2) Gb
II 2 D Ex h IIIC T100°C...T200°C Db
 - Metal pump models with external aluminum components (E-series, VL Series, VMD Series)
 - Versa-Surge® surge suppressors (VTA-Series)

- I M2 Ex h Mb
-  II 2 G Ex h IIC T5...225°C (T2) Gb
II 2 D Ex h IIIC T100°C...T200°C Db
 - Metal pump models with no external aluminum (E-Series)
 - Conductive plastic pumps (E-Series, VMV Series Plastic)

-  II 2 G Ex h IIB T5...225°C (T2) Gb
II 2 D Ex h IIIB T100°C...T200°C Db
 - E1 HP & E2 HP Series due to the projected area of non-conductive external air hoses

2. AODD Pumps - EU Type Examination Certificate No.: DEKRA 18ATEX0094X - DEKRA Certification B.V. (0344)
Meander 1051

Hazardous Location Applied:

6825 MJ Arnhem
The Netherlands

- I M1 Ex h I Ma
-  II 1 G Ex h IIC T5...225°C (T2) Ga
II 1 D Ex h IIIC T100°C...T200°C Da
 - Conductive plastic pumps equipped with conductive muffler (VMV Series)

➤ See "Safety Information" page for conditions of safe use

Dennis Hall
Engineering Manager

DATE/APPROVAL/TITLE:
9 NOV 2023



VERSAMATIC®

UKEx



EU Declaration of Conformity

Manufacturer:

Warren Rupp, Inc.
A Unit of IDEX Corporation
800 North Main Street
Mansfield, OH 44902 USA

This declaration of conformity is issued under the sole responsibility of the manufacturer.
Warren Rupp, Inc declares that Air Operated Double Diaphragm Pumps (AODD) and Surge Suppressors listed below comply with the requirements of United Kingdom Statutory Instruments **2016 No. 1107** and all the applicable standards.

Designated Standards:

- EN ISO 80079-36: 2016
- EN ISO 80079-37: 2016

1. AODD Pumps and Surge Suppressors - Technical File on record with: DEKRA Certification UK Limited
Stokenchurch House
Oxford Road
Stokenchurch
HP14 3SX

Hazardous Location Applied:



- II 2 G Ex h IIC T5...225°C (T2) Gb
- II 2 D Ex h IIIC T100°C...T200°C Db
- Metal pump models with external aluminum components (E-series, VL Series, VMD Series)
- Versa-Surge® surge suppressors (VTA-Series)



- I M2 Ex h Mb
- II 2 G Ex h IIC T5...225°C (T2) Gb
- II 2 D Ex h IIIC T100°C...T200°C Db
- Metal pump models with no external aluminum (E-Series)
- Conductive plastic pumps (E-Series, VMV Series Plastic)



- II 2 G Ex h IIB T5...225°C (T2) Gb
- II 2 D Ex h IIIB T100°C...T200°C Db
- E1 HP & E2 HP Series due to the projected area of non-conductive external air hoses

➤ See "Safety Information" page for conditions of safe use

DATE/APPROVAL/TITLE:
9 NOV 2023

Dennis Hall
Engineering Manager



Declaration of Compliance

Manufacturer: Warren Rupp, Inc., 800 N. Main Street, Mansfield, Ohio, 44902 USA
 certifies that the below Air-Operated Double Diaphragm Food Processing Pump Models and
 Tranquilizer® Surge Suppressor Models comply with the European Community Regulations:
 (EC) No 1935/2004 for Food Contact Materials
 (EC) No 2023/2006 Good Manufacturing Practice
 (EU) No 10/2011 on plastic materials and articles intended to come in contact with food

Sanitary Pump Models:

E#S#5#54###-SP	E#S#7#54###-SP	E#S#Y#54###-SP
E#S#5#55###-SP	E#S#7#55###-SP	E#S#Y#55###-SP
E#S#5#57###-SP	E#S#7#57###-SP	E#S#Y#57###-SP
E#S#5#5S###-SP	E#S#7#5S###-SP	E#S#Y#5S###-SP
E#S#5#5Y###-SP	E#S#7#5Y###-SP	E#S#Y#5Y###-SP
E#S#5#74###-SP	E#S#7#74###-SP	E#S#Y#74###-SP
E#S#5#75###-SP	E#S#7#75###-SP	E#S#Y#75###-SP
E#S#5#77###-SP	E#S#7#77###-SP	E#S#Y#77###-SP
E#S#5#7S###-SP	E#S#7#7S###-SP	E#S#Y#7S###-SP
E#S#5#7Y###-SP	E#S#7#7Y###-SP	E#S#Y#7Y###-SP
E#S#5#S4###-SP	E#S#7#S4###-SP	E#S#Y#S4###-SP
E#S#5#S5###-SP	E#S#7#S5###-SP	E#S#Y#S5###-SP
E#S#5#S7###-SP	E#S#7#S7###-SP	E#S#Y#S7###-SP
E#S#5#SY###-SP	E#S#7#SY###-SP	E#S#Y#SY###-SP
E#S#5#Y4###-SP	E#S#7#Y4###-SP	E#S#Y#Y4###-SP
E#S#5#Y5###-SP	E#S#7#Y5###-SP	E#S#Y#Y5###-SP
E#S#5#Y7###-SP	E#S#7#Y7###-SP	E#S#Y#Y7###-SP
E#S#5#YS###-SP	E#S#7#YS###-SP	E#S#Y#YS###-SP

Food Processing Pump Models:

E#S#5#55###-FP	E#S#7#55###-FP	E#S#Y#55###-FP
E#S#5#57###-FP	E#S#7#57###-FP	E#S#Y#57###-FP
E#S#5#5S###-FP	E#S#7#5S###-FP	E#S#Y#5S###-FP
E#S#5#5Y###-FP	E#S#7#5Y###-FP	E#S#Y#5Y###-FP
E#S#5#75###-FP	E#S#7#75###-FP	E#S#Y#75###-FP
E#S#5#77###-FP	E#S#7#77###-FP	E#S#Y#77###-FP
E#S#5#7S###-FP	E#S#7#7S###-FP	E#S#Y#7S###-FP
E#S#5#7Y###-FP	E#S#7#7Y###-FP	E#S#Y#7Y###-FP
E#S#5#S5###-FP	E#S#7#S5###-FP	E#S#Y#S5###-FP
E#S#5#S7###-FP	E#S#7#S7###-FP	E#S#Y#S7###-FP
E#S#5#SY###-FP	E#S#7#SY###-FP	E#S#Y#SY###-FP
E#S#5#Y5###-FP	E#S#7#Y5###-FP	E#S#Y#Y5###-FP
E#S#5#Y7###-FP	E#S#7#Y7###-FP	E#S#Y#Y7###-FP
E#S#5#YS###-FP	E#S#7#YS###-FP	E#S#Y#YS###-FP

Surge Suppressor Models:

VDA051SPTNS00	VTA2,NG2SS.	VTA40,NG1SS.
VTA1 1/2,NG1SS.	VTA25,NG1SS	VTA50,NG2SS.
VTA1,NG1SS.	VTA3,NG2SS.	VTA80,NG2SS.

- Materials used in equipment intended for food contact (Annex I (EC) No 1935/2004) :
 - Rubber • Metals & Alloys • Plastics

Plastic Materials: PTFE and FKM/ PTFE coated

The plastic components are suitable to come in contact with multiple food types, provided that storage contact time does not exceed 1/2 hour, contact temperature does not exceed 40°C and maximum operating temperatures within the instructions manual are not exceeded. Diaphragm failure may allow process fluids to come in contact with nonconforming materials. Regular inspections are recommended.

- This Declaration is based on :
 - Declaration of Conformities from raw material suppliers
 - Total Migration Analysis per (EU) No 10/2011
- Supporting document will be made available to competent authorities to demonstrate compliance

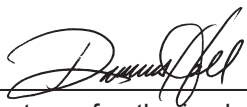

 Signature of authorized person

Dennis Hall

 Printed name of authorized person

February 8, 2013

 Date of issue

Engineering Manager

 Title

October 3, 2022

 Date of revision

