



Aseptic Valves

GEA VESTA® bellows valve type H_A/T Sizes DN10 to ISO 33,7

Operating instruction (Translation from the original language)

430BAL008602EN_4

COPYRIGHT

These Operating Instructions are the English translation of the original operating instructions in the sense of the EU Machinery Directive. This document is protected by copyright. All rights reserved. The document may not, in whole or in part, be copied, reproduced, translated or reduced to an electronic medium of machine-readable form without the express permission of GEA Tuchenhausen GmbH.

LEGAL NOTICE

Word marks

The designations VESTA® and T.VIS® are protected trademarks of GEA Tuchenhausen GmbH.

TABLE OF CONTENTS

1	General Information	5
1.1	Information on the Document	5
1.1.1	Binding Character of These Operating Instructions	5
1.1.2	Notes on the Illustrations	5
1.1.3	Symbols and Highlighting	5
1.2	Manufacturer address	6
1.3	Contact	7
1.4	EU Declaration of Conformity in accordance with the EC Machinery Directive 2006/42/EC	8
1.5	Translated copy of the EU - Declaration of conformity in accordance with the Machinery Directive 2006/42/EU	9
2	Safety	10
2.1	Intended use	10
2.1.1	Requirements for operation	10
2.1.2	Pressure equipment directive	10
2.1.3	Use in potentially explosive atmospheres (ATEX)	10
2.1.4	Improper operating conditions	11
2.2	Operator's Duty of Care	11
2.3	Subsequent changes	12
2.4	General safety instructions and dangers	12
2.4.1	Principles for safe operation	12
2.4.2	Environmental Protection	12
2.4.3	Electrical Equipment	13
2.5	Supplementary Regulations	13
2.6	Qualification of personnel	13
2.7	Safety equipment	15
2.7.1	Signs	15
2.8	Residual dangers	16
2.9	Danger zones	17
3	Description	19
3.1	Design	19
3.2	Functional description	21
3.2.1	Closing direction NC	21
3.2.2	Distinguishing feature of spring-to-close actuator (NC)	21
3.2.3	Closing direction NO	21
3.2.4	Distinguishing feature of spring-opening actuator (NO)	22
4	Transport and storage	23
4.1	Storage conditions	23
4.2	Transport	23
4.2.1	Scope of supply	23
5	Technical data	24
5.1	Type plate	24
5.2	Technical data	24
5.3	Resistance of the sealing materials	27
5.4	Pipe ends - General table of measurements	28
5.5	Tool	29
5.6	Lubricants	29
5.7	Weights	29
6	Start-up	31
6.1	Safety precautions	31
6.2	Notes on commissioning	31
7	Operation and control	32
7.1	Safety instructions	32
8	Assembly and installation	33
8.1	Safety instructions	33
8.2	Notes on installation	33
8.3	Control head	33
8.4	Valve with detachable pipe connection elements	33
8.5	Weld valve with housing connection	34
8.6	Welding the valve housing	36

8.7	Pneumatic connections	38
8.7.1	Air requirement	38
8.7.2	Establishing Hose Connections	38
8.8	Electrical connection with T.VIS control top	39
9	Cleaning	40
9.1	Cleaning	40
9.2	Passivation	40
9.3	Sterilisation	40
10	Maintenance	41
10.1	Safety instructions	41
10.2	Inspections	42
10.2.1	Leakage openings	42
10.2.2	Pneumatic connection	42
10.2.3	Electrical connections	42
10.3	Servicing intervals	43
10.4	Disassembling the Valve	44
10.4.1	Prior to disassembly	44
10.4.2	Removing the valve insert	44
10.4.3	Removing the bellows	47
10.4.4	Disassembling the visual position indicator	48
10.4.5	Disassembling the pneumatic actuator	48
10.4.6	Removing the control top T.VIS V-1/P-1	54
10.4.7	Removing the manual actuator	55
10.5	Maintenance	55
10.5.1	Note on Seal Replacement	55
10.5.2	Cleaning the valve	55
10.5.3	Lubricating seals and threads	56
10.6	Installation	58
10.6.1	Mounting the pneumatic actuator	58
10.6.2	Assembling the visual position indicator	62
10.6.3	Installing the control top T.VIS V-1 / P-1	64
10.6.4	Mounting the bellows	65
10.6.5	Installing the valve insert	66
10.6.6	Checking the function	68
11	Alarms	69
11.1	Malfunctions and remedies	69
12	Decommissioning	71
12.1	Safety instructions	71
12.2	Disposal	71
12.2.1	General notes	71
13	Dimension sheet - VESTA sterile valves tank bottom valve H_A/T/H	72
14	Spare parts list - VESTA sterile valves tank bottom valve H_A/T	76
15	Spare parts list -mounting for proximity switch H_A	84
16	Spare parts list - welding jig H_A/T and T_A	86
17	Dimension sheet - VESTA sterile valves tank bottom valve H_A/T	87
18	Dimension sheet - VESTA sterile valves tank bottom valve H_A/T/H	89
19	Dimension sheet - housing connection H_A/T/F	91
20	Welding instruction housing H_A/T for VESTA tank bottom valves DN10 to DN32; ISO13.5 to ISO33,7; 0.5"OD to 1"OD	95
21	Appendix	97
21.1	Lists	97
21.1.1	Abbreviations and terms	97

1 General Information

1.1 Information on the Document

The present Operating Instructions are part of the user information for the product. The Operating Instructions contain all the information you need to transport, install, commission, operate and carry out maintenance for the product.

1.1.1 Binding Character of These Operating Instructions

These Operating Instructions contain the manufacturer's instructions to the operator of the product and to all persons who work on or use the product regarding the procedures to follow.

Carefully read these Operating Instructions before starting any work on or using the product. Your personal safety and the safety of the product can only be ensured if you act as described in the Operating Instructions.

Store the Operating Instructions in such a way that they are accessible to the operator and the operating staff during the entire life cycle of the product. When the location is changed or the product is sold make sure you also provide the Operating Instructions.

1.1.2 Notes on the Illustrations

The illustrations in these Operating Instructions show the product in a simplified form. The actual design of the product can differ from the illustration. For detailed views and dimensions of the product please refer to the design documents.

1.1.3 Symbols and Highlighting

In these Operating Instructions, important information is highlighted by symbols or special formatting. The following examples illustrate the most important types of highlighting.



Danger

Warning: Fatal Injuries

Failure to observe the warning can result in serious damage to health, or even death.

- ▶ The arrow identifies a precautionary measure you have to take to avoid the hazard.



Warning: Explosions

Failure to observe the warning can result in severe explosions.

- ▶ The arrow identifies a precautionary measure you have to take to avoid the hazard.
-

 **Warning!**

Warning: Serious Injuries

Failure to observe the warning can result in serious damage to health.

- ▶ The arrow identifies a precautionary measure you have to take to avoid the hazard.

 **Caution!**

Warning: Injuries

Failure to observe the warning can result in minor or moderate damage to health.

- ▶ The arrow identifies a precautionary measure you have to take to avoid the hazard.

Notice

Warning: Damage to Property

Failure to observe the warning can result in serious damage to the component or in the vicinity of the component.

- ▶ The arrow identifies a precautionary measure you have to take to avoid the hazard.

Carry out the following steps: = Start of a set of instructions.

1. First step in a sequence of operations.
 2. Second step in a sequence of operations.
 - Result of the previous operation.
- The operation is complete, the goal has been achieved.

 **Hint!**

Further useful information.

1.2 Manufacturer address

GEA Tuchenhausen GmbH
Am Industriepark 2-10
21514 Büchen

1.3 Contact

Tel.:+49 4155 49-0
Fax:+49 4155 49-2035
flowcomponents@gea.com
www.gea.com

General Information

EU Declaration of Conformity in accordance with the EC Machinery Directive 2006/42/EC

1.4 EU Declaration of Conformity in accordance with the EC Machinery Directive 2006/42/EC



EU Declaration of conformity within the meaning of the EC machine directive 2006/42/EC

Manufacturer: **GEA Tuchenhagen GmbH**
Am Industriepark 2-10
21514 Büchen, Germany

Hereby, we declare that the machine designated in the following

Designation: Valve with actuator

Type: VESTA® H_A, H_AI, H_AT

by virtue of its design and construction and in the versions placed on the market by us, complies with the essential health and safety requirements of the following directive:

Relevant EC directives: 2006/42/EC EC Machinery Directive

Applicable harmonized standards, in particular: EN ISO 12100: 2010

- Remarks:
- In the event of a modification to the machine that was not agreed with us, this declaration loses its validity
 - Furthermore, we declare that the specific technical documentation for this machine has been drawn up in accordance with Annex VII, Part A, and undertake to forward this documentation by means of data medium upon justified request by the national authorities

Person authorised for compilation and handover of technical documentation:

GEA Tuchenhagen GmbH
CE Documentation Officer
Am Industriepark 2-10
21514 Büchen, Germany

Büchen, 19 September 2023

Tatjana Fischer
Managing Director

pp. Stephan Dirks
Head of Engineering

1.5 Translated copy of the EU - Declaration of conformity in accordance with the Machinery Directive 2006/42/EU

Manufacturer: GEA Tuchenhagen GmbH
Am Industriepark 2-10
21514 Büchen, Germany

We hereby declare that the machine named below

Designation: Valve with actuator
Type: H_A, H_AI, H_AT

due to its design and construction as well as in the versions sold by us, meet the basic safety and health requirements of the following guideline:

Relevant EC directives: 2006/42/EC EC Machinery Directive
Applicable harmonized standards, in particular: DIN EN ISO 12100

Remarks: This declaration will become invalid if any alterations are made to the machine which have not been agreed with us. We also declare that the relevant technical documentation for this machine has been prepared in accordance with Annex VII, Part A, and agree to submit the documentation on justified request of national authorities on a data carrier.

Person authorised for compilation and handover of technical documentation: GEA Tuchenhagen GmbH
CE Documentation Officer
Am Industriepark 2-10
21514 Büchen, Germany

Büchen, 19 September 2023

Tatjana Fischer
Managing
Director

i.V. Stephan Dirks
Head of Engineering

2 Safety

2.1 Intended use

Tank bottom valves of type H_A/T are stroke valves and are used for controlled opening and closing tank outlets.

The valve is monitored, controlled and operated by the operator's installation.

Pressure hammers and excessive control air pressures can destroy the bellows. Therefore, the control air pressure should not exceed the maximum value according to the technical data.



Hint!

The manufacturer will not accept any liability for damage resulting from any use of the valve which is not in accordance with the designated use of the valve. The risk is borne solely by the operating company.

2.1.1 Requirements for operation

The prerequisite for reliable and safe operation of the component is proper transportation and storage as well as professional installation and assembly. Operating the unit within the limits of its designated use also involves adhering to the operating, inspection and maintenance instructions.

2.1.2 Pressure equipment directive

The component is a piece of pressure equipment (without safety function) in the sense of the pressure equipment directive 2014/68/EU. Classified according to Annex II in category 1.

According to the scope of directive 2014/34/EC, article 1, paragraph 2, f, the exception of the directive applies, due to conformity with the machine directive 2006/42/EU.

The nominal diameters smaller than DN 25 are subject to article 4, paragraph 3 of the Pressure Equipment Directive which specifies sound engineering practice. Nominal diameters \geq IPS 4"; DN 125 valid for the fluid group II.

In the event of any deviations, GEA Tuchenhausen GmbH will supply a specific Declaration of Conformity.

2.1.3 Use in potentially explosive atmospheres (ATEX)

In areas with an explosive atmosphere, only valves suitable for use in such areas may be used.

Refer to and observe the additional instruction manual "Hygienic valves ATEX models". For details regarding the marking of valves for use in potentially explosive areas also refer to the additional instruction manual "Hygienic valves ATEX models".

If these valves are used in areas with a potentially explosive atmosphere, you must absolutely comply with the requirements of directive 2014/34/EC with respect to all ignition hazards.

2.1.4 Improper operating conditions

The operational safety of the component can not be guaranteed under improper operating conditions. Therefore avoid improper operating conditions.

The operation of the component is not permitted if:

- Persons or objects are in the danger zone.
- Safety devices are not working or were removed.
- Malfunctions have been detected on the component.
- Damage to the component has been detected.
- Maintenance intervals have been exceeded.

2.2 Operator's Duty of Care

The operating company of the component has a special responsibility for the proper and safe handling of the component within their company. Only use the component when it is in perfect operating condition in order to prevent danger to persons and property.

This operating manual contains information that you and your employees need for safe operation over the life of the component. Be sure to read these Operating Instructions carefully and ensure that the measures described here are observed.

The operator's duty of care includes planning the necessary safety measures and monitoring that these measures are observed. The following principles apply:

- Only qualified personnel may work on the component.
- The operating company must authorize personnel to carry out the relevant tasks.
- Order and cleanliness must be maintained at the work stations and in the entire area surrounding the component.
- Personnel must wear suitable work clothing and personal protective equipment. As the operating company must ensure that work clothing and personal protective equipment are used.
- Inform personnel regarding any properties of the product which might pose a health risk and the preventative measures to be taken.
- Have a qualified first-aid representative on call during the operation. This person must be able to initiate any necessary first-aid measures in case of an emergency.
- Clearly define procedures, competences and responsibilities for those working in the area of the component. Everybody must know what to do in case of an emergency. Instruct the staff in this respect at regular intervals.
- The signs on the component must always be complete and easy to read. Check, clean and replace the signs as necessary at regular intervals.
- Observe the Technical Data specified and the limits of use!



Hint!

Carry out regular checks. This way you can ensure that these measures are actually observed.

2.3 Subsequent changes

No technical modifications should ever be made to this component. Otherwise you will have to undergo a new conformity process in accordance with the EC Machinery Directive on your own.

In general, only original spare parts supplied by GEA Tuchenhausen GmbH should be fitted. This ensures that the component is always operating properly and efficiently.

2.4 General safety instructions and dangers

The component is safe to operate. It was built according to state-of-the-art science and technology.

Nevertheless, dangers can arise from the component, if:

- the component is not used as intended
- the component is used improperly
- the component is operated under impermissible conditions

2.4.1 Principles for safe operation

Dangerous situations during operation can be avoided by safety-conscious and proactive behaviour of the staff.

To ensure safe operation of the valve the following principles apply:

- The Operating Instructions must be kept ready to hand at the valve's place of use. They must be complete and in clearly legible form.
- Only use the valve for its intended use.
- The valve must be functional and in good working order. Check the condition of the valve before starting work and at regular intervals.
- Wear tight-fitting work clothing for all work on the valve.
- Ensure that nobody can get hurt on the parts of the valve.
- Immediately report any faults or noticeable changes on the valve to the person responsible.
- Never touch the pipes and the valve when these components are hot! Avoid opening the valve unless the process plants have been emptied and depressurised.
- Observe the accident prevention regulations and all local regulations.

2.4.2 Environmental Protection

Harm to the environment can be avoided by safety-conscious and proactive behaviour of the staff.

For environmental protection the following principles apply:

- Substances harmful to the environment must not be discharged into the ground or the sewage system.
- Always observe the pertinent regulations relating to waste avoidance, disposal and utilization.
- Substances harmful to the environment must be collected and stored in suitable containers. Clearly mark the containers.
- Dispose of lubricants as hazardous waste.

2.4.3 Electrical Equipment

For all work on electrical equipment, the following principles apply:

- Access to electrical equipment should only be allowed to qualified electricians. Always keep unattended switch cabinets locked.
- Modifications of the control system can affect the safe and reliable operation. Modifications are only permitted with the express permission of the manufacturer.
- After completion of all work, check that the protective devices are fully functional.

2.5 Supplementary Regulations

In addition to the instructions in this documentation the following also has to be observed:

- pertinent accident prevention regulations,
- generally accepted safety rules,
- national regulations applicable in the country of use,
- work and safety instructions applicable in the facility,
- installation and operating regulations for use in potentially explosive areas.

2.6 Qualification of personnel

This section provides information on how the personnel working on the component must be trained.

Operating and maintenance personnel must

- have the necessary qualification to carry out their tasks,
- be instructed with regard to possible dangers,
- know and observe the safety instructions given in the documentation.

Only allow qualified electricians to carry out work on the electrical equipment or have a qualified electrician supervise the work.

Only allow specially trained personnel to carry out work on an explosion-protected system. When working on explosion-protected equipment observe the standards DIN EN 60079-14 for gases and DIN EN 50281-1-2 for dusts.

The following minimum qualifications are required:

- Training as a specialist for working independently on the component.
- Adequate instruction to work on the component under the supervision and guidance of a trained specialist

Each employee must meet the following requirements to work on the component:

- Personal suitability for the respective task.
- Sufficient professional qualification for the respective task.
- Received instruction about the functionality of the component.
- Received instruction about operating sequences on the component.
- Familiar with the safety devices and their function.
- Familiar with these Operating Instructions, especially with the safety instructions and the information which is relevant for the task on hand.
- Familiar with the basic regulations with regard to occupational health and safety and accident prevention.

When working with the component, a distinction is made between the following user groups:

User groups	
Staff	Qualifications
Operating personnel	<p>Adequate instruction and sound knowledge in the following areas:</p> <ul style="list-style-type: none"> • Functionality of the component • Operating sequences on the pump • What to do in case of an emergency • Lines of authority and responsibilities with respect to the task
Maintenance personnel	<p>Appropriate training and a sound knowledge of the structure and functionality of the component.</p> <p>Sound knowledge in the following areas:</p> <ul style="list-style-type: none"> • Mechanical equipment • Electrical equipment • Pneumatic system <p>Authorization with regard to safety engineering standards to carry out the following tasks:</p> <ul style="list-style-type: none"> • Setting devices into operation • Earthing of devices • Marking of devices <p>The relevant certificates of qualification must be submitted before work can be carried out on ATEX certified machines.</p>

2.7 Safety equipment

2.7.1 Signs

Hazardous locations on the component are marked by warning labels, prohibition signs and mandatory signs.

The signs and instructions on the component must always be legible. Any illegible signs must be replaced immediately.

Signs on the component	
Sign	Meaning
	Explosion-hazard zones warning

2.8 Residual dangers

Dangerous situations can be avoided by safety-conscious and proactive behaviour of the personnel and by wearing personal protective equipment.

Residual dangers on the valve and measures		
Danger	Cause	Measure
Danger to life	Inadvertent switch-on of the valve	Effectively disconnect all components, effectively prevent switch-on.
	Electric power	Observe the following safety rules: <ol style="list-style-type: none"> 1. Isolate from the power supply. 2. Take appropriate measures to prevent switch on. 3. Test absence of voltage. 4. Earthing and short-circuiting. 5. Cover or safeguard any adjacent live parts.
	Spring tension in the actuator	For large valves: Danger to life caused by the pressurised spring in the actuator. Do not open the actuator, rather return it to GEA Tuchenhagen for proper disposal.
Risk of injury	Danger presented by moving or sharp-edged parts	<p>The operator must exercise caution and prudence.</p> <p>For all work:</p> <ul style="list-style-type: none"> • Wear suitable work clothing. • Never operate the machine if the cover panels are not correctly fitted. • Never open the cover panels during the operation. • Never reach into openings. <p>As a precautionary measure, wear personal protective equipment in the vicinity of the valve:</p> <ul style="list-style-type: none"> • Protective gloves • Safety shoes

Residual dangers on the valve and measures		
Danger	Cause	Measure
	Danger due to escaping media at the leakage hole	<ul style="list-style-type: none"> Effectively disconnect all components. Effectively prevent switching on. Pipes must be depressurised.
Environmental damage	Operating materials with properties which are harmful to the environment	For all work: <ul style="list-style-type: none"> Collect lubricants in suitable collecting vessels. Dispose of lubricants in accordance with the pertinent regulations.

2.9 Danger zones

Please observe the following notes:

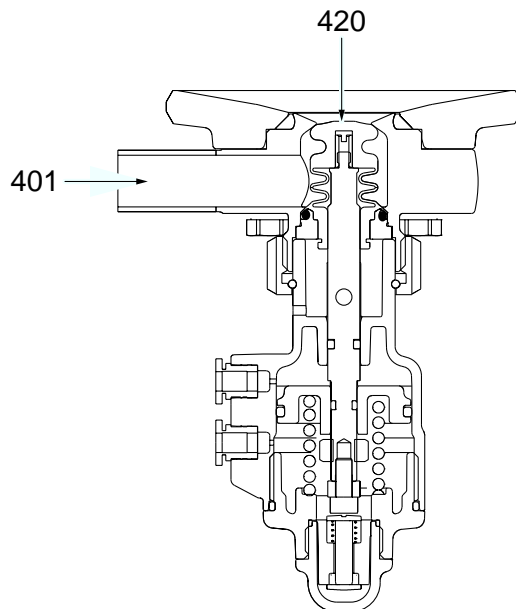

Fig.1: Hazard areas on the valve, housing for flange mounting

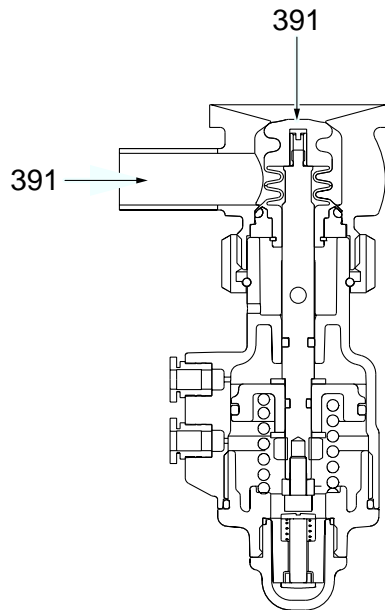

Fig.2: Hazard areas on the valve, housing for welding

- In the event of malfunctions, shut down the valve (disconnect from the power and air supply) and secure it against being used.
- Before starting any maintenance, servicing or repair work, disconnect the valve from the power supply and secure it against inadvertently being switched back on again.
- Only allow a qualified electrician to carry out any work on the electrical power supply.
- Check the electrical equipment of the valve at regular intervals. Immediately remedy loose connections and molten cables.
- If work on live parts cannot be avoided, call in a second person, who can operate the main switch in case of an emergency.
- The housing connection piece (401), (391) and the housing connection (420) have very sharp edges. Never put your hands in.
- When transporting and installing the valve be sure to wear suitable protective gloves.

3 Description

3.1 Design

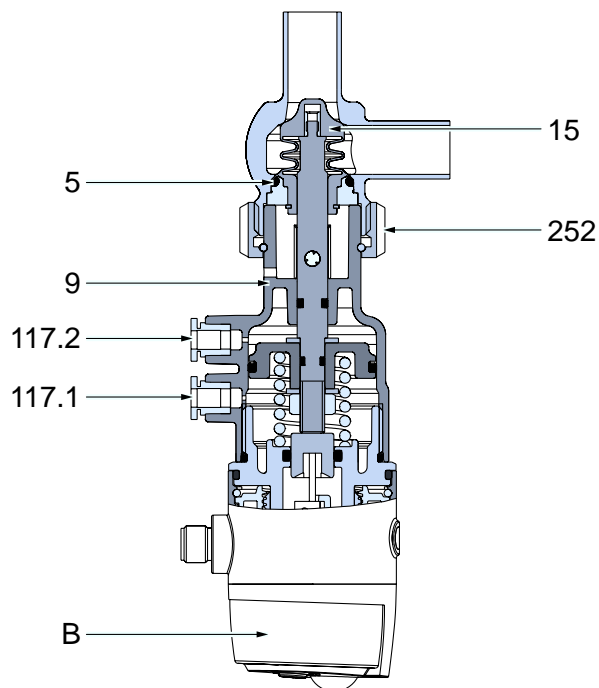

Fig.3: Valve for welding in, with control top

Design	
No.	Designation
15	Bellows
9	Lantern
252	Cap nut (safety device)
117.2	Air connection NO
117.1	Air connection NC

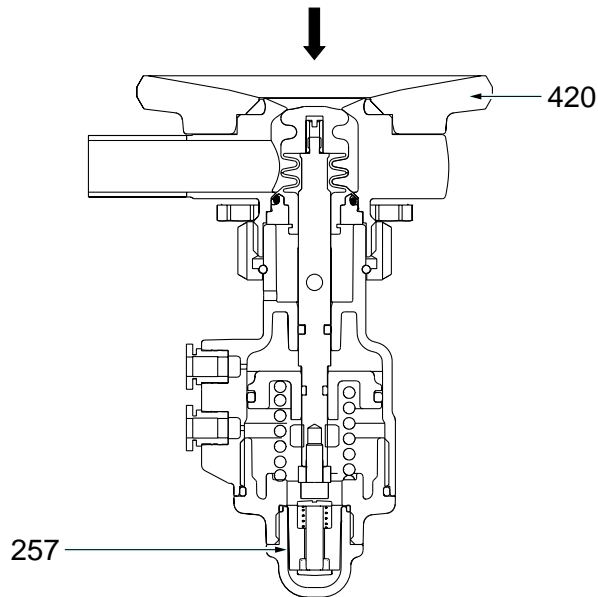

Fig.4: Valve for flange mounting, with position indicator, flow direction from the top

Design	
No.	Designation
420	Housing connection
257	Position indicator

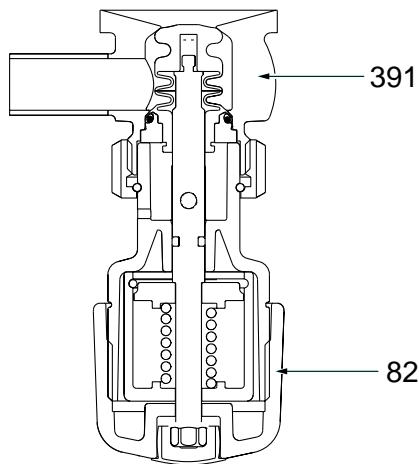

Fig.5: Valve for welding in, with manual actuator

Design	
No.	Designation
391	Valve housing
82	Handwheel

3.2 Functional description

3.2.1 Closing direction NC

Closing direction: from top to bottom

Resting position: spring closing

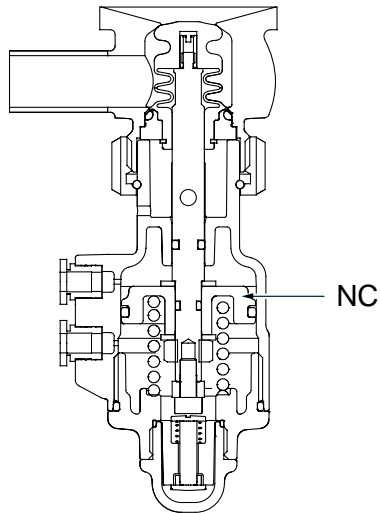

Fig.6: Resting position (NC). Valve with mechanical position indicator

3.2.2 Distinguishing feature of spring-to-close actuator (NC)

Valve is closed in the non-actuated position.

Identification on the T.VIS control top once the installation (SET-UP) has been completed:

- Permanent light (1) green: valve in non-actuated position
- Permanent light (1) yellow: valve in end position (actuated position)

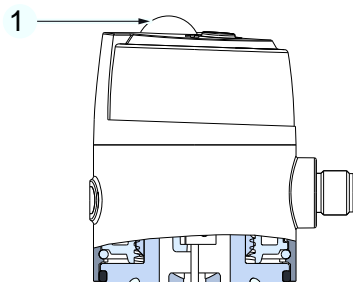

Fig.7: Permanent light on the control top T.VIS

3.2.3 Closing direction NO

Closing direction: from the bottom to the top

Resting position: spring opening

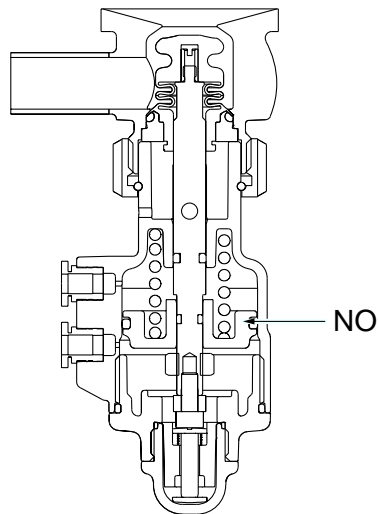

Fig.8: Resting position (NO), valve with mechanical position indicator

3.2.4 Distinguishing feature of spring-opening actuator (NO)

The valve is open in the non-actuated position.

Identification on the T.VIS control top once the installation (SET-UP) has been completed:

- Green steady light (1): valve in non-actuated position
- Yellow steady light (1): valve in end position (actuated position)

4 Transport and storage

4.1 Storage conditions

The valves, valve inserts or spare parts should be stored in a dry place, free of vibrations and dust, and protected from light. To avoid damage, leave the components in their original packaging if possible.

If, during transport or storage, the valve is going to be exposed to temperatures $\leq 0^{\circ}\text{C}$, it must be dried beforehand and suitable measures must be taken to protect it from damage.



Hint!

We recommend that the valve should be stored at a temperature of $\geq 5^{\circ}\text{C}$ for a period of 24 hours prior to any handling (disassembling the housings / activation of actuators) so that any ice crystals formed by condensation water can melt.

4.2 Transport

For transport, the following principles apply:

- Only use suitable hoist and slings for transporting the package units/valves.
- Observe the pictograms on the package.
- Handle valves with care to avoid damage caused by impact or careless loading and unloading. The outside synthetic materials are susceptible to breaking.
- Control tops must be protected from animal and vegetable fats.
- Only allow qualified staff to transport the valve.
- Movable parts must be properly secured.
- Under no circumstances should anyone stand under a suspended load.
- Take care when transporting the valve. Do not grip sensitive parts of the unit to lift or push the unit or to support yourself. Avoid jerky movements when putting down the unit.

4.2.1 Scope of supply

After taking delivery of the component, check if

- the details on the type plate correspond to the data in the order and delivery documents,
- the equipment is complete and all components are in good order.

5 Technical data

5.1 Type plate

The type plate clearly identifies the valve.

GEA Tuchenhagen GmbH Am Industriepark 2-10, 21514 Büchen, Germany			
min/max Air press			
operation press.		2021	
SD			
Type H-A/T-			

Fig.9

The type plate provides the following key data:

Key data of the valve	
Control air pressure bar/psi	minimum 5.0/72; maximum 6.0/87
Product pressure bar/psi	6.0/87
Serial	Serial number
Mat.	Material number
Type	Tank bottom valve H_A/T, H_A/T/F

5.2 Technical data

Refer to the following tables for the key technical data of the valve:

Technical data: Valve	
Designation	Description
Size	DN 10 to DN 32 0.5" OD to 1" OD ISO 13,5 to ISO 33,7
Material of product contact parts	Stainless steel 1.4435, PTFE
Fitting position	Any position, if valve and pipe system can drain properly

Technical data: Ambient temperatures	
Designation	Description
- Valve	0 to +60 °C, standard < 0 °C: Use control air with low dew point. Protect valve rods against freezing. < -15 °C: no solenoid valves in the control top > +50 °C: no solenoid valves in the control top
- Initiator	-20 to +80 °C
- Control top type T.VIS M-15, A-15	-20 to +50 °C
- Control top type T.VIS P-15	0 to +60 °C
Product temperature and operating temperature	0 to +135 °C short-term +150°C, maximum for 30 minutes

Technical data: Compressed air supply	
Designation	Description
Air hose	
- metric	Material PE-LD outside Ø 6 mm Inside Ø 4 mm
- Inch	Material PA outside-Ø 6.35 mm Inside Ø 4.3 mm
Product pressure	10 bar (145 psi) standard
Control air pressure	Actuator NC: 6 bar, max 8 bar Actuator NO: 5 bar Actuator LL: 4 bar
Control air	acc. to ISO 8573-1:2010
- Solid particle content:	Quality class 6 Particle size max. 5 µm Particle density maximum 5 mg/m ³
- Water content:	Quality class 4, maximum dew point +3 °C If the unit is used at higher altitudes or at low ambient temperatures, an accordingly lower dew point is required.
- Oil content:	Quality class 3, preferably oil free maximum 1 mg oil in 1m ³ air

Note: Compressed air support when using valves with NC actuator not permitted.

5.3 Resistance of the sealing materials

The resistance of sealing materials depends on the type and temperature of the medium conveyed. The exposure time can adversely affect the service life of the seals. The sealing materials meet the requirements of the respective directives for the food industry and the pharmaceutical industry. See material certificates for more information.

Resistance:

- + = good resistance
- o = reduced resistance
- – = no resistance

Seal resistance PTFE				
Medium	Temperature	Sealing material (general operation temperature)	Sealing material (general operation temperature)	Sealing material (general operation temperature)
		PTFE TFM1705	MOD LW-NFF	HS22212
Alkalis up to 3%	up to 80 °C (176°F)	+	+	+
Alkalis up to 5%	up to 40 °C (104°F)	+	+	+
Alkalis up to 5%	up to 80 °C (176° F)	+	+	+
Alkalis more than 5%		+	+	+
Inorganic acids up to 3%	up to 80 °C (176°F)	+	+	+
Inorganic acids up to 5%	up to 80 °C (176°F)	+	+	+
Inorganic acids up to 5%	up to 100 °C (212°F)	+	+	+
Water	up to 80 °C (176°F)	+	+	+
Steam	up to 135 °C (275° F)	+	+	+
Steam, approx. 30 min	up to 150 °C (320°F)	+	+	+
Fuels/hydrocarbons		+	+	+
Product with a fat content of max. 35%		+	+	+
Product with a fat content of more than 35%		+	+	+
Oils		+	+	+

5.4 Pipe ends - General table of measurements

The following information refers to pipe ends. More measurements can be found in the measurement tables in .



Hint!

The valves are also available in larger nominal sizes, see the operating instructions "GEA VESTA(R) shut-off valves type H_A XL".

Dimensions for tubes in DN				
Metric DN	Outside diameter	Wall thickness	Inside diameter	Outside diameter according to DIN 11866 series A
10	13	1.5	10	x
15	19	1.5	16	x
20	23	1.5	20	x
25	29	1.5	26	x
32	35	1.5	32	x

Dimensions for tubes in inch OD				
Inch OD	Outside diameter	Wall thickness	Inside diameter	Outside diameter acc. to DIN 11866 series C
0.5"	12.7	1.65	9.4	x
0.75"	19.05	1.65	15.75	x
1"	25.4	1.65	22.1	x

Dimensions for tubes in ISO				
ISO	Outside diameter	Wall thickness	Inside diameter	Outside diameter according to DIN 11866 series B
13.5	13.5	1.6	10.3	x
17.2	17.2	1.6	14	x
21.3	21.3	1.6	18.1	x
26.9	26.9	1.6	23.7	x
33.7	33,7	2	29.7	x

5.5 Tool

List of tools	
Tool	Material no.
Open-ended wrench, a/f 17-19	408-037
Open-ended wrench, a/f 22-24	408-039
Manual emergency actuator	221.310.74
Hose cutter	407-065
Vice with protective jaws	--
Protective gloves, heat-resistant	
Allen key, size 10	408-126
Circlip pliers, angled at 90° for circlip	--

5.6 Lubricants

Lubricants	
Lubricants	Material no.
Cassida P1	413-134

5.7 Weights

Weights	
Size	Weight [kg], valve HLA/T, for welding
DN 10	0.86
DN 15	0.84
DN 20	1.85
DN 25	2.47
DN 32	...
OD 0.5"	0.86
OD 0.75"	0.84
OD 1"	1.85
ISO 13.5	0.86
ISO 17.2	0.84
ISO 21.3	1.85
ISO 26.9	1.84
ISO 33.7	2.47

Weights	
Size	Weight [kg], valve HLA/T/F, for flange mounting
DN 10	2.07
DN 15	2.05
DN 20	3.81
DN 25	4.43
DN 32	...
OD 0.5"	2.07
OD 0.75"	2.05
OD 1"	3.81
ISO 13.5	2.07
ISO 17.2	2.06
ISO 21.3	3.81
ISO 26.9	3.80
ISO 33.7	4.43

6 Start-up

6.1 Safety precautions

Initial commissioning

For initial commissioning, the following principles apply:

- Carry out protective measures against dangerous contact voltages in accordance with the applicable regulations.
- The components must be fully assembled and properly adjusted. All screw connections must be securely tightened. All electrical cables must be installed correctly.
- Reliably secure machine parts which have already been connected against inadvertently being switched on.
- Relubricate all lubricating points.
- Make sure lubricants are used properly.
- After a modification of the components a reassessment of residual risks is required.

Commissioning

For commissioning, the following principles apply:

- Only qualified personnel may commission the components.
- Make sure all connections are properly established.
- The safety devices on the component must be completely installed, in working order and function properly. Check the function before starting any work.
- When switching on the component, the danger zones must be clear.
- Remove any liquids that have escaped without leaving residues.

6.2 Notes on commissioning

Before starting commissioning observe the following:

- Make sure that there are no foreign materials in the system.
- Actuate the component once by applying compressed air.
- Clean the pipe system prior to the first product run.
- During commissioning, regularly check all sealing points for leaks. Replace defective seals.

7 Operation and control

7.1 Safety instructions

Dangerous situations during operation can be avoided by safety-conscious and proactive behaviour of the personnel.

For operation, the following principles apply:

- Monitor the component during operation.
- Safety devices must not be changed, removed or taken out of service. Check all safety devices at regular intervals.
- All guards and hoods must be fitted as intended.
- The installation location of the component must always be properly ventilated.
- Structural changes to the component are not permitted. Report any changes to the component immediately to the person in charge.
- Always keep danger zones clear. Do not leave any objects in the danger zone. Only allow persons to enter the danger zone when the machine is de-energized.
- Regularly check that all emergency stop devices are working correctly.

8 Assembly and installation

8.1 Safety instructions

Hazardous situations during installation can be avoided by safety-conscious and proactive behaviour of the personnel.

For installation, the following principles apply:

- Only qualified personnel are allowed to set-up, install and commission the component.
- Ensure that adequate working and traffic areas are available at the place of installation.
- Observe the maximum load-bearing capacity of the installation surface.
- Observe the transport instructions and markings on the part(s) to be transported.
- Remove any nails protruding from transport crates immediately after opening the crate.
- Under no circumstances should anyone stand under a suspended load.
- Safety devices of the component may not work effectively during installation.
- Reliably secure sections of the plant which have already been connected against inadvertently being switched on.

8.2 Notes on installation

The valve is installed under the tank. Care must be taken to ensure that the valve housing and the pipe system can drain properly.

To prevent damage, make sure that:

- the valve is installed between the tank and the pipe system free of tension and
- no foreign materials (e.g. tools, bolts, lubricants) are left in the system.

8.3 Control head

If external valves are connected in a control top with several solenoid valves, make sure that the control air pressure in the main actuator does not fall below the operating pressure.

8.4 Valve with detachable pipe connection elements

This section describes the procedure to fit the valve.

Caution!

Liquids in pipes

Danger of injury due to liquid spraying out

- ▶ Before releasing any pipe or hinged clamp connections: drain and, if necessary, clean or flush the pipe.
 - ▶ Separate the pipe section in which the valve is to be fitted from the rest of the piping system to prevent product entering again.
-

Notice

Seals are wearing parts

Old seals will cause malfunction of the valve

- ▶ When fitting the valve be sure to carry out a visual check of the condition of the sealing surface.
-

Carry out the following steps:

1. Fit valves with detachable pipe connection elements – using suitable connection fittings – directly into the pipe system.
→ Valve is installed.

8.5 Weld valve with housing connection

This section describes the welding procedure for the housing connection and valve housing H_A/T/F.



Warning!

Spring tension in the valve

Danger of injury when detaching the cap nut at the housing as the released spring pretension will suddenly lift the actuator.

- ▶ Therefore, release the spring tension before detaching the cap nut by supplying the actuator with compressed air at max. 8 bar.
-

Notice

Welding distortions

An open housing can warp during welding.

- ▶ To avoid welding distortions, always seal the housing before welding.
-

Welding housing connection

If the valves are delivered with screwed in housing connection H_A/T/F (420), first undo the screws (206) and the housing connection (420).

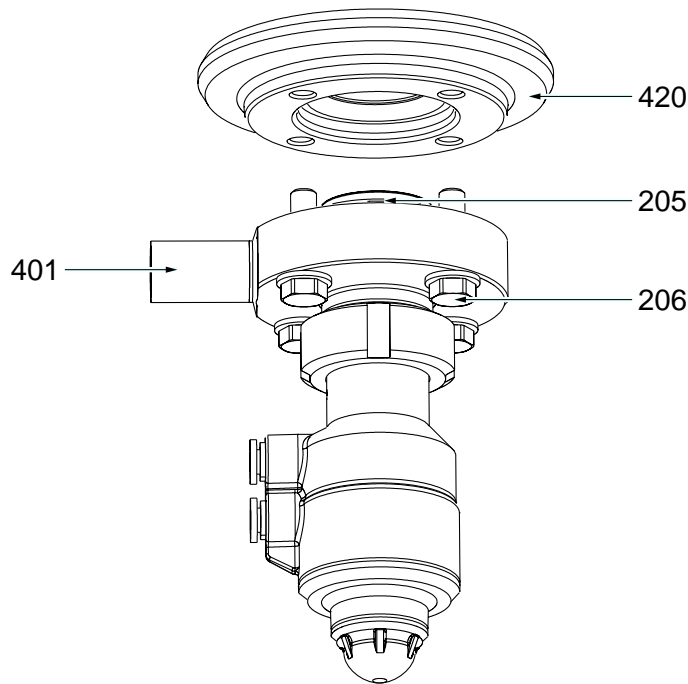

Fig.10: Valve with screwed-on housing connection

Carry out the following steps:

1. Weld the housing connection (420) into the tank bottom.



Hint!

Use a welding jig when welding, see spare parts list 221ELI004121G attached. Pay attention to the welding instructions (WPS) 221RLI004112D for the housing connection valve H_A/T/F, see annex.

Welding the valve housing

Carry out the following steps:

1. Release the spring tension.
2. Remove the valve insert, see chapter Section 10.4, Page 44.
3. Fit the housing and fix it in several places around the circumference.
4. To avoid welding distortions, always seal the housing before welding.
5. Flush the housing with forming gas from the inside to push the oxygen out of the system.
6. Weld the housing into the pipe system; use welding filler if necessary. When technically possible, use the WIG-orbital welding process with pulse configuration, according to guidelines EHEDG documentation. 35.
7. Passivate the seam after welding.
8. Assemble the valve and vent the actuator.
 - The bellows is lowered.
 - Valve with housing connection is installed.



Hint!

Welding method: We recommend using the automatic orbital welding method. All welding work should only be performed by certified welders or machine operators (orbital welders).

8.6 Welding the valve housing

This section describes the welding procedure for the H_A/T valve housing.



Warning!

Spring tension in the valve

Danger of injury when detaching the cap nut at the housing as the released spring pretension will suddenly lift the actuator.

- ▶ Therefore, release the spring tension before detaching the cap nut by supplying the actuator with compressed air at max. 8 bar.
-

Notice

Welding distortions

An open housing can warp during welding.

- ▶ To avoid welding distortions, always seal the housing before welding.
-

Welding the housing

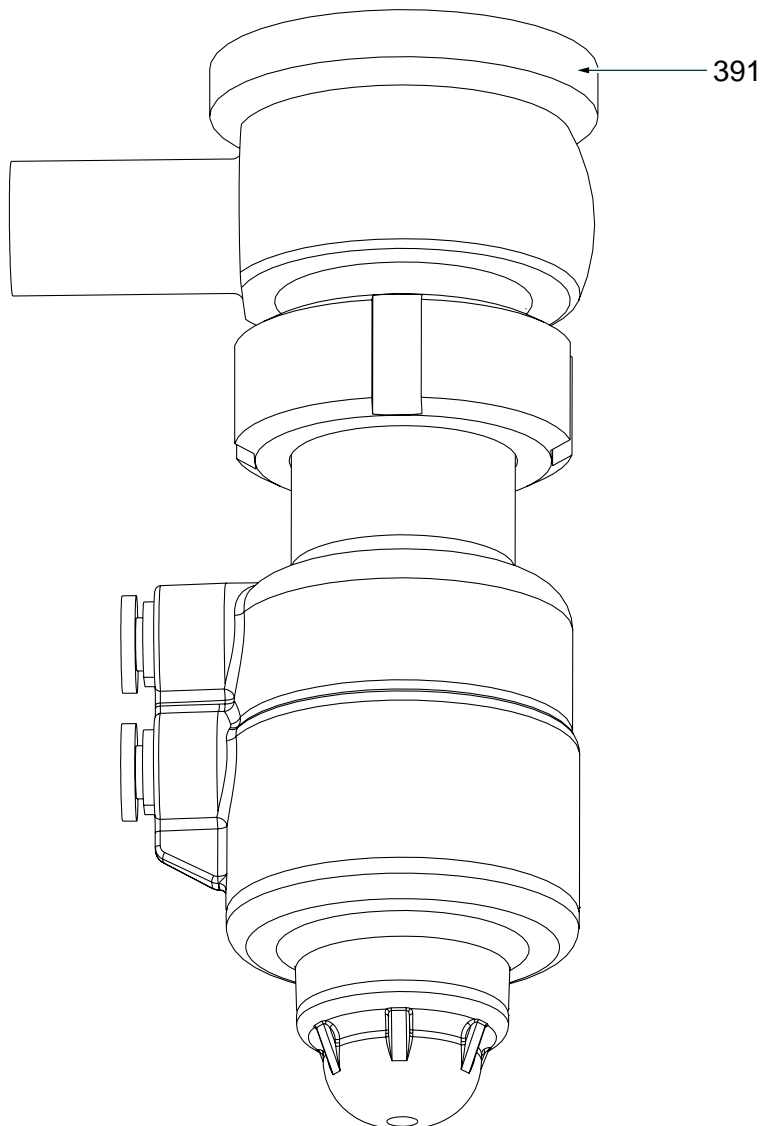

Fig.11: Welding the valve housing

Carry out the following steps:



Hint!

When welding the housing (391) into the tank bottom, pay attention to the welding instructions (WPS) 221RLI004129D, see annex.

1. Release the spring tension.
2. Remove the valve insert, see chapter Section 10.4, Page 44.
3. Fit the housing and fix it in several places around the circumference.
4. To avoid welding distortions, always seal the housing before welding.
5. Flush the housing with forming gas from the inside to push the oxygen out of the system.

6. Weld the housing into the pipe system; use welding filler if necessary. When technically possible, use the WIG-orbital welding process with pulse configuration, according to guidelines EHEDG documentation. 35.
7. Passivate the seam after welding.
8. Assemble the valve and vent the actuator.
 - The bellows is lowered.
 - Valve is installed.



Hint!

Welding method: We recommend using the automatic orbital welding method. All welding work should only be performed by certified welders or machine operators (orbital welders).

8.7 Pneumatic connections

8.7.1 Air requirement

Actuator Ø [mm]	Air requirement (dm ³ _n /stroke) dm ³ _n at 1.01325 bar at 0 °C as per DIN 1343
DN 10	0.011
DN 15	0.013
DN 20	0.02
DN 25	0.038
DN 32	0.038
1/2" OD	0.011
3/4" OD	0.013
1" OD	0.02
ISO 13.5	0.011
ISO 17.2	0.014
ISO 21.3	0.019
ISO 26.9	0.02
ISO 33.7	0.038

8.7.2 Establishing Hose Connections

To ensure reliable operation, the compressed air hoses must be cut exactly square.

Tools required:

- A hose cutter

Carry out the following steps:

1. Shut off the compressed air supply.
 2. Use the hose cutter to cut the pneumatic hoses square.
 3. Push the air hose into the air connector on the control top.
 4. Re-open the compressed air supply.
- Establish a hose connection.

8.8 Electrical connection with T.VIS control top



Danger

Live parts

Electrical shock can result in serious personal injury or death.

- ▶ Only allow properly qualified staff to carry out work on the electrical equipment.
- ▶ Prior to establishing electrical connections check the maximum permissible operating voltage.



Explosive gases or dusts

An explosion can result in serious personal injury or death.

- ▶ Observe the installation and operating regulations for use in potentially explosive areas.

Carry out the following steps:

1. Connect in accordance with the connection diagram and the instructions in the corresponding operating instructions for control tops T.VIS M-15, A-15 or T.VIS P-15.

→ Done



Hint!

The proximity switches are factory set. During transport and installation it can happen that the settings are changed, so that readjustment may be required (see the Operating Instructions for the control top).

9 Cleaning

9.1 Cleaning

All parts in contact with product must be cleaned at regular intervals. Always observe the safety data sheets issued by the cleaning agent manufacturers. Only use cleaning agents which do not cause damage to the seals and the inner parts of the valve. When the pipe is cleaned, the cleaning medium also flows through and cleans the valve housings.

With respect to the cleaning method and parameters like detergents, temperatures, times, and intervals, the component manufacturer can merely make recommendations but cannot provide any generally applicable details. Method and parameters should be determined and defined by the operator in accordance with the relevant process and product.

The cleaning effect must be checked regularly by the operator!

9.2 Passivation

Before commissioning a plant, passivation is commonly carried out for long pipes and tanks.

Valve blocks are usually excepted from this. Passivation is typically performed using nitric acid (HNO₃) at approx. 80 °C (176 °F) at a concentration of 3 % and a contact time of 6 to 8 hours.

9.3 Sterilisation

The valve is suitable for SIP sterilisation (sterilisation in place).

The permissible sterilisation media and temperatures for the various sealing materials are listed in the resistance table, see . Other sterilisation media (e.g. H₂O₂) must be approved by the manufacturer.



Hint!

VESTA® bellows achieve optimal sealing only after an initial SIP cleaning.

- Medium: saturated steam
- Temperature: 135 °C (275 °F)
- Switching: clockwise during the SIP process

The valve must be brought to the closed position for a brief period (min. 3 seconds) immediately SIP cleaning. During commissioning, regularly check all sealing points for leaks. Exchange defective seals and repeat the SIP process.

10 Maintenance

10.1 Safety instructions

Maintenance and repair

Before carrying out maintenance and repair work on the component's electrical equipment, perform the following steps in accordance with the "5 safety rules":

- Isolate from the power supply
- Take appropriate measures to prevent switch on
- Test absence of voltage
- Earthing and short-circuiting
- Cover or safeguard any adjacent live parts.

For maintenance and repair, the following principles apply:

- Observe the intervals specified in the maintenance schedule.
- Only qualified personnel may carry out maintenance or repair work on the component.
- The component must be switched off and secured against being switched back on before maintenance or repair work. Work may only be started once any residual energy has been discharged.
- Block access for unauthorized persons. Put up notice signs which draw attention to the maintenance or repair work going on.
- Do not climb on the component. Use suitable access aids and working platforms.
- Wear suitable protective clothing.
- Only use suitable and undamaged tools to carry out maintenance work.
- When replacing parts only use approved, fully functional load lifting devices and lifting accessories which are suitable for the intended purpose.
- Before setting the unit back into operation, refit all safety devices as originally provided in the factory. Then check that all safety devices are working correctly.
- Make sure lubricants are used properly.
- Check pipes are firmly secured, also check for leaks and damage.
- Check that all emergency stop devices are working correctly.

Disassembly

For disassembly, the following principles apply:

- Only qualified personnel are allowed to dismantle the component.
- The component must be switched off and secured against being switched back on before it is dismantled. Work may only be started once any residual energy has been discharged.

- Disconnect all power and utility lines.
- Markings, e.g. on lines, must not be removed.
- Do not climb on the component. Use suitable access aids and working platforms.
- Mark the lines (if unmarked) prior to disassembly to ensure they are not confused when re-assembling.
- Protect open line ends with blind plugs against ingress of dirt.
- Pack sensitive parts separately.
- For longer periods of standstill, observe the storage conditions, see Section 4.1, Page 23.

10.2 Inspections

Between the maintenance periods, the components must be checked for leakage and proper function.

10.2.1 Leakage openings

Carry out the following steps:

1. Check the leakage opening regularly to determine if they are free of contamination
 2. Check the leakage cavity for soiling and continuous leakage of fluids.
- Done

10.2.2 Pneumatic connection

Carry out the following steps:

1. Check the operating pressure at the pressure reducing and filter station.
 2. Regularly clean the air filter in the filter station.
 3. Check that the air hoses sit firmly in the air connections.
 4. Check the lines for kinks and leaks.
 5. Check the solenoid valves for proper function.
- Note: When the control top is mounted, it must be actuated.
- Done

10.2.3 Electrical connections

Carry out the following steps:

1. Check that the union nut on the cable gland is tight
 2. Check that the cable connections are firmly secured.
 3. Check the solenoid valves for proper function.
- Note: When the control top is mounted, it must be actuated.
4. Check that the initiator connections are clean.

→ Done



Hint!

The electrical cable must be long enough to allow the control top to be removed via the switch bar!

10.3 Servicing intervals

To ensure the highest operational reliability of the valves, all wearing parts should be replaced at longer intervals. Keep an adequate supply of all wearing parts (bellows and seals) in your spare parts stock.

In practice, the actual maintenance intervals can only be determined by the user since they depend on the operating conditions.

Examples of relevant process parameters are:

- daily period of use,
- switching frequency,
- type and temperature of the product,
- type and temperature of the cleaning solution,
- ambient conditions.

If there is still no or too little information available for the definition of practically-orientated maintenance intervals, the reference values listed in the following table can be considered as a basis. The following information is based on the experience of GEA Flow Components and applies to installations working in a 2-shift operation.

Servicing intervals	
Component	Measure
Maintenance activities to be performed once a month	
Valve	Visual check without dismantling
Maintenance activities to be performed after 3 months	
Product contact seals	Media temperature 60...130 °C (140...266 °F)
	Seal replacement
Actuator	Function check
Valve	Function check
Feedback	Function check
Pneumatic connections	Check of mechanical parts and visual inspection of condition – leak test
Electrical connections	Visual inspection
Maintenance activities to be performed once a year	

Servicing intervals	
Component	Measure
Product contact seals	Media temperature < 60 °C (< 140 °F)
	Seal replacement
Actuator	Mechanical & visual inspection of condition
Valve	Check of mechanical parts and visual inspection of condition – function test
Feedback	Check of mechanical parts and visual inspection of condition – function test
Pneumatic connections	Check of mechanical parts and visual inspection of condition – function test
Electrical connections	Check of mechanical parts and visual inspection of condition

10.4 Disassembling the Valve

10.4.1 Prior to disassembly

Prerequisite:

- Make sure that during maintenance and repair work no process is in operation in the area concerned.

Carry out the following steps:

1. Drain all pipe system elements that lead to the valve and, if necessary, clean or rinse them.
2. Disconnect the power supply.
3. Take the valve out of the pipe section, with all housings and housing connections if possible.

→ Done

10.4.2 Removing the valve insert

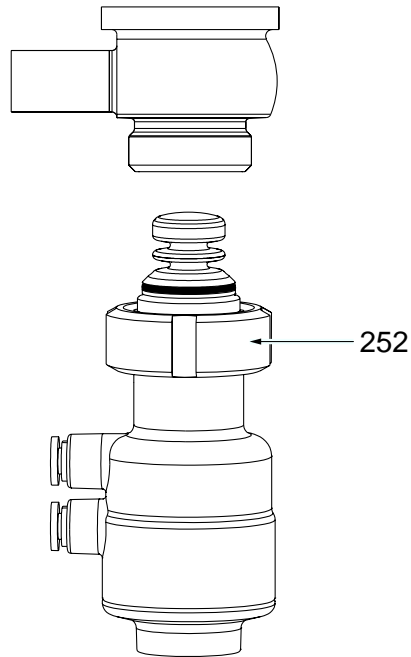

Fig.12: Valve insert with bellows

Requirement:

- No solenoid valve must be actuated electrically or manually.

Spring-closing valve NC

⚠ Warning!

Spring tension in the valve

Danger of injury when detaching the cap nut (252) at the housing as the released spring pretension will suddenly lift the actuator.

- ▶ Therefore, release the spring tension before detaching the cap nut by supplying the actuator with compressed air at max. 8 bar.

Notice

The potentiometer spindle (P) is a sensitive component

Damage to potentiometer spindle (P)

- ▶ Handle potentiometer spindle (P) carefully
- ▶ Do not remove the hood (H) of the control top (B). Do not disassemble the attachments 1+2 of the control top for air/air actuators.

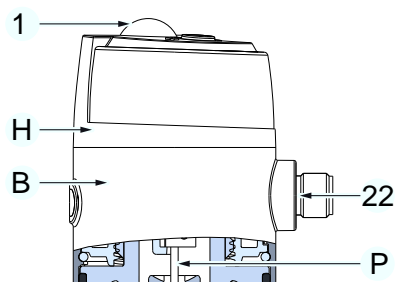

Fig.13: Control top T.VIS V-1

Carry out the following steps:

1. Remove electrical and pneumatic connections from the control top (B).
 2. Vent actuator at connection (117) with compressed air, max. 8 bar.
→ The bellows (15) are raised.
 3. Undo the cap nut (252) using the joint spanner and remove the valve insert.
! Do not hit the valve parts against the housing.
 4. Interrupt the compressed air supply.
→ The bellows (15) are lowered.
- Done

Spring-opening valve NO

Carry out the following steps:

1. Remove electrical and pneumatic connections from the control top (B).
 2. Undo the cap nut (252) using the joint spanner and remove the valve insert.
! Do not hit the valve parts against the housing.
- Done

10.4.3 Removing the bellows

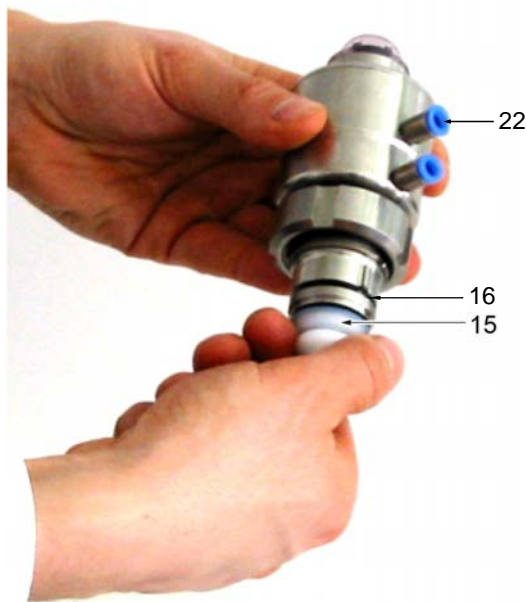

Fig.14: Removed valve seat

⚠ Warning!

Spring tension in spring-opening valve (NO)

Danger of injury.

- ▶ Do not put your hand into the valve housing.
- ▶ Before removing the valve insert, pressurise connection (22) with air.

⚠ Warning!

In the case of a removed valve insert, (NC) and (NO), there is a risk of injury at point (16).

There is a risk of crushing or clamping.

- ▶ Do not reach into the gap at point (16)!

Carry out the following steps:

1. Unscrew bellows (15) from the valve rod.
→ This completes removal of the bellows.

10.4.4 Disassembling the visual position indicator

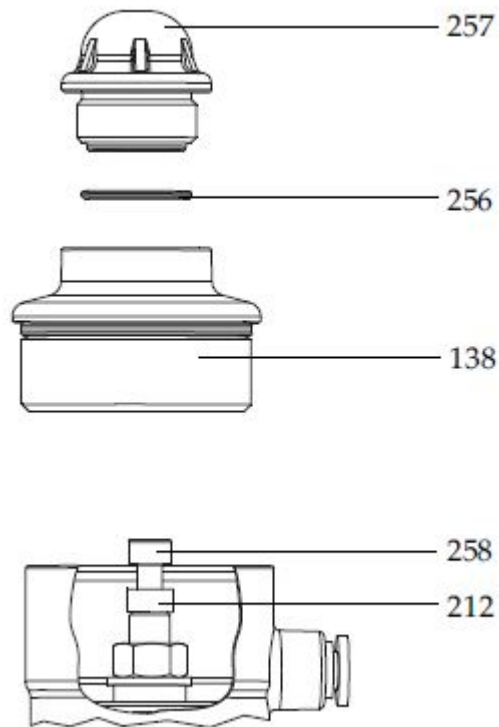

Fig.15: Pneumatic actuator with visual position indicator

Carry out the following steps:

1. Unscrew the position indicator (257) using tools.
 2. Take the O-ring (256) out of the housing (138).
 3. Remove spacer (212) and screw (258).
- Visual position indicator is disassembled.

10.4.5 Disassembling the pneumatic actuator



Hint!

For valves in stainless steel, unscrew the screw-in slip connections (117) (hexagon socket AF 2.5).

Removing Actuator NC–spring-closing

Carry out the following steps:

1. Unscrew cover (138) with screwdriver (hexagon socket) AF17.

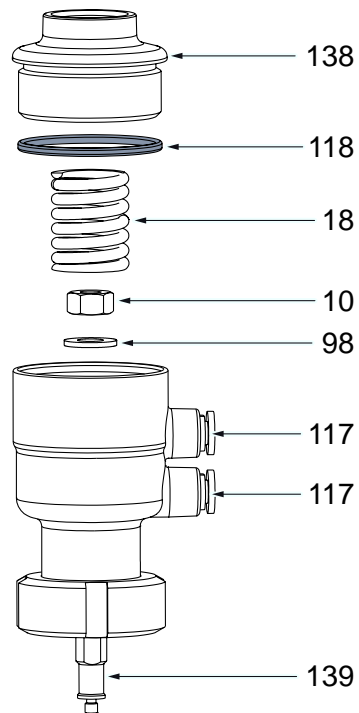

Fig.16: Components pneumatic actuator (1)

2. Take the O-ring (118) out of the housing (138).
3. Remove the compression spring (18), undo the hexagon nut (10) (socket wrench insert) and slide off the rod (139) with the washer (98).
4. Pull the rod (139) down and out of the lantern (9).
5. Push the piston (228) with a screwdriver up and out of the lantern, also remove the washer (98).

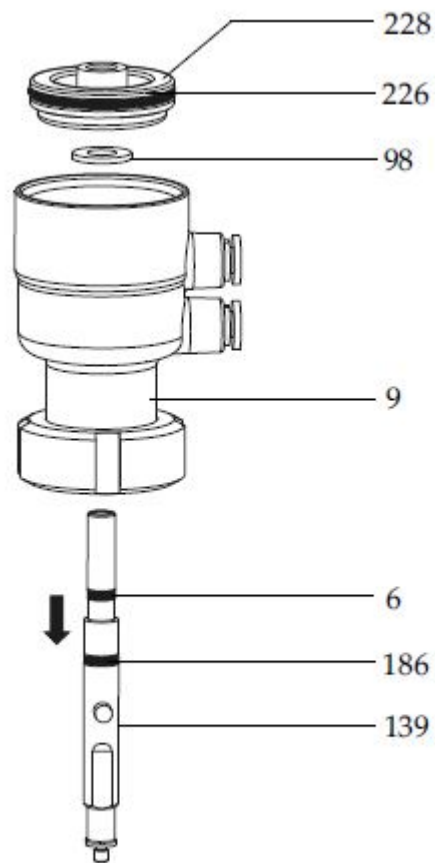

Fig.17: Components pneumatic actuator (2)

6. Remove the O-rings 226, 6, 186.

- For the stainless steel version, the anti-twist protection can be removed to replace the O-ring (29). To this end, push the pin (251) inwards, the rod must already be removed for this. Remove the sleeve (219) downwards and remove the O-ring (29).

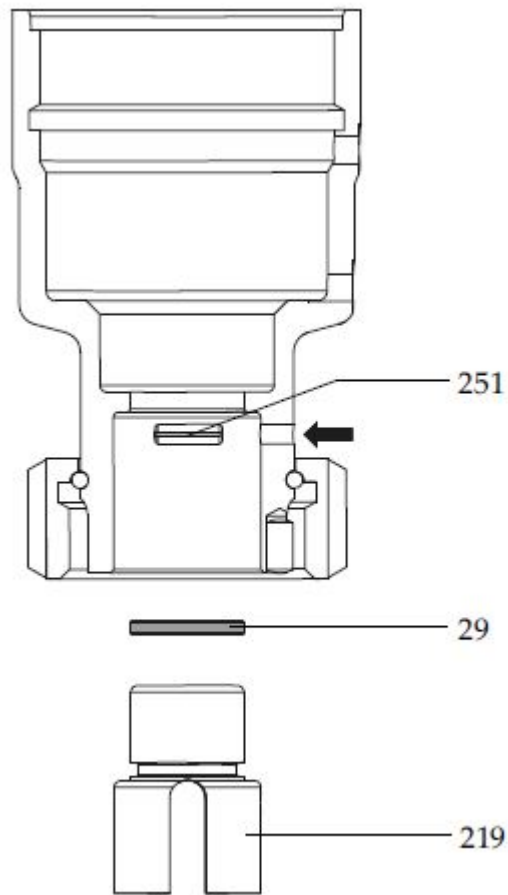

Fig.18: Lantern pneumatic actuator

→ Actuator NC–spring-closing has been removed.

Removing the actuator NO–spring-closing

1. Unscrew cover (138) with screwdriver (hexagon socket) AF17.

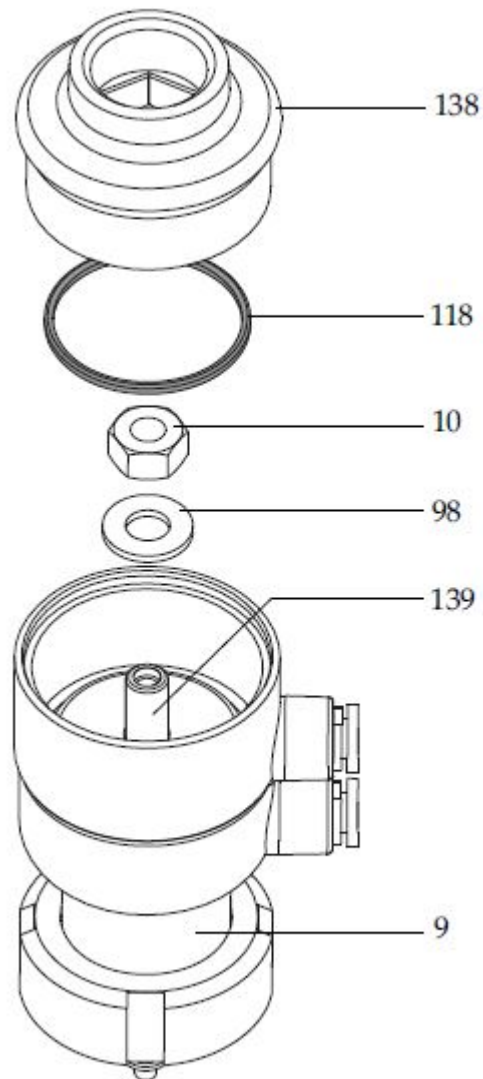

Fig.19: Components pneumatic actuator (3)

2. Removing the O-ring (118).
3. Undo the hexagon nut (10) (socket wrench insert). This relieves the pressure spring (18). Slide the washer (98) off the rod (139).
4. Pull the rod (139) down and out of the lantern (9).

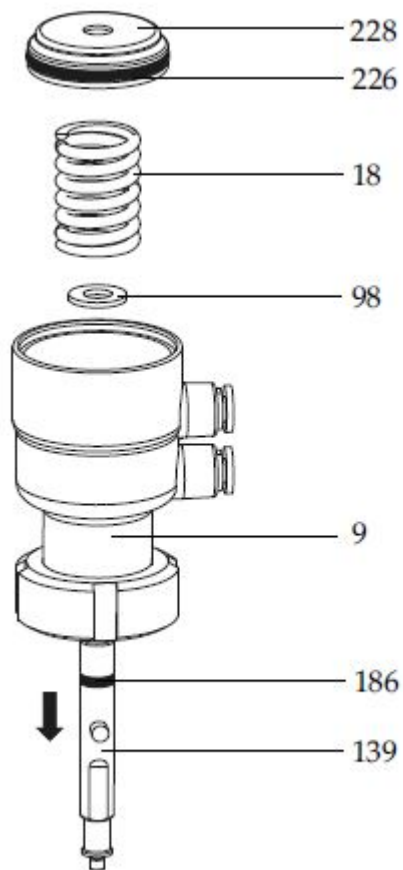

Fig.20: Components pneumatic actuator (4)

5. Remove the piston (228) together with the pressure spring (18) and the washer (98).
 6. Remove the O-rings (226, 6, 186).
- Actuator NO–spring-opening has been removed.

10.4.6 Removing the control top T.VIS V-1/P-1

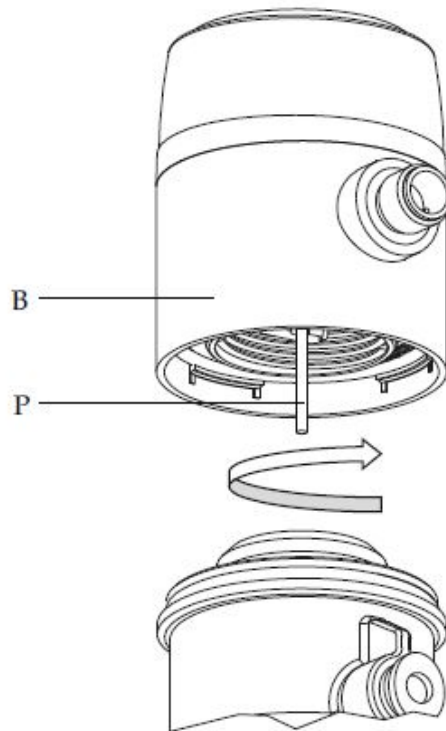

Fig.21: Control top T.VIS V-1

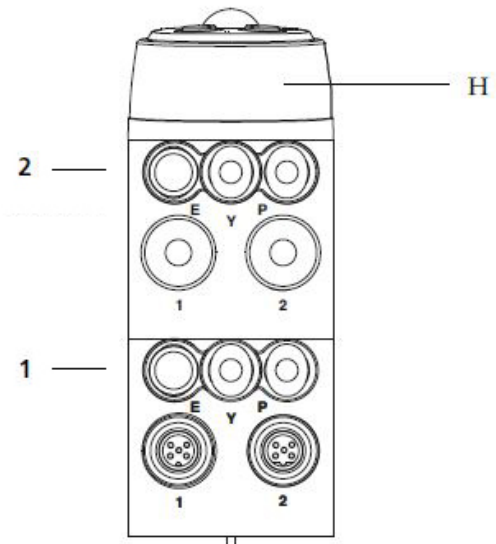

Fig.22: Control top T.VIS P-1, attachment 1 and 2

Notice

The potentiometer spindle (P) is a sensitive component

Damage to potentiometer spindle (P)

► Handle potentiometer spindle (P) carefully

Carry out the following steps:

1. Remove electrical and pneumatic connections from the control top (B).
 - Do not remove the hood (H) of the control top (B).
 - Do not disassemble the attachments 1 and 2 for control tops for air/air actuators.
 2. Turn the control top (B) to the left (in the direction of the arrow) until the stop is reached.
- Control top T.VIS V-1/P-1 has been removed.

10.4.7 Removing the manual actuator

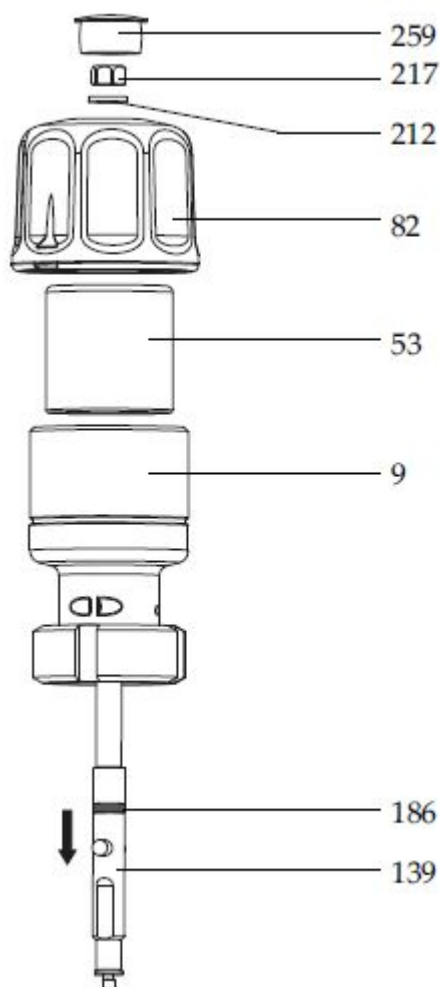

Fig.23: Components manual actuator

Carry out the following steps:

1. Remove the round plug (259), unscrew the hexagon nut (217) AF13 together with the washer (212).
 2. Unscrew the handwheel(82), remove the spring package (53) upwards, pull out rod (139) downwards.
 3. Remove the O-ring (186).
- Manual actuator has been removed.

10.5 Maintenance

10.5.1 Note on Seal Replacement

Replace defective seals and bellows to ensure the tightness of the valve. Always use genuine spare parts. Follow maintenance procedures with regard to the seals, see Section 10.3, Page 43.

10.5.2 Cleaning the valve

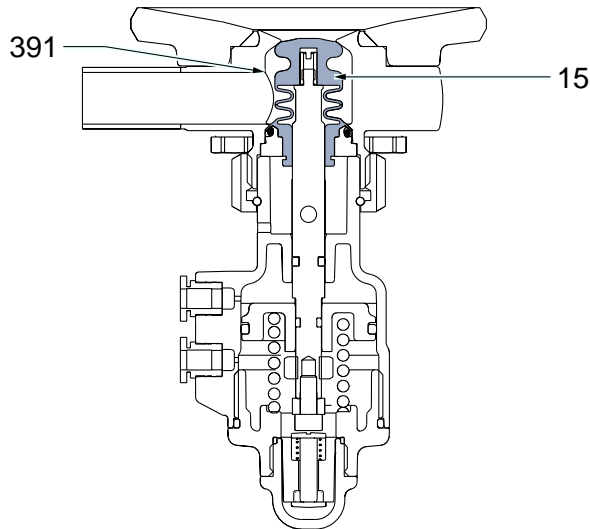

Fig.24: Shut-off valve with pneumatic actuator

Notice

The bellows with valve shaft (15) and housing seat (391) are precision areas. They may not be damaged!

Damage to these parts can result in malfunction.

- ▶ Handle the valve with care!

Notice

Damage to the valve

Damage to these parts can result in malfunction.

- ▶ Observe the safety information sheets issued by the detergent manufacturers!
- ▶ Only use detergents which are non-abrasive and not aggressive towards stainless steel.



Hint!

With plastic actuators made from PPS, the operator must pay particular attention to the selection of a suitable cleaning agent. We also recommend replacing the PP plastic actuator after 2 years.

Carry out the following steps:

1. Disassemble the valve, see Section 10.4, Page 44.
 2. Carefully clean the individual parts.
- Done

10.5.3 Lubricating seals and threads

 **Caution!**

Damage to seals and threads

Damage to seals and threads can result in malfunction.

- ▶ Ensure that an adequate film of lubricant is applied. No grease residues must be visible once the valve has been assembled completely.
- ▶ For product contact seals only use suitable greases and oils.
- ▶ Observe the safety data sheets issued by the lubricant manufacturer.

Carry out the following steps:

1. Lightly grease the valve rod thread.
2. Grease all seals – including the O-rings of the actuator – very thinly.
!Do not grease the bellows and the O-ring behind it.

→ Done

 **Hint!**

GEA Tuchenhausen recommends Cassida P1. This lubricant is food grade and has NSF-H1 (USDA H1) registration. It does not affect the taste or the consistency of the products and is compatible with the seals in contact with product.

Cassida P1 can be ordered from GEA Tuchenhausen under material no. 413-134. Using other types of grease can result in malfunctions or in premature seal failure. The warranty will also become null and void.

A Manufacturer's Declaration for these products can be obtained from GEA Tuchenhausen if required.

A thin film of grease is required on the seals to ensure the proper function of the fittings. It reduces friction and extends the service life of the seals. This is absolutely harmless from a health and hygienic point of view.

Running dry must be avoided!

10.6 Installation

10.6.1 Mounting the pneumatic actuator



Hint!

For valves in stainless steel, screw on the screw-in slip connections (117) (hexagon socket AF 2.5) after the installation.

Assembling the actuator NC–spring-closing

Carry out the following steps:

Fit the anti-rotation device for stainless steel model.

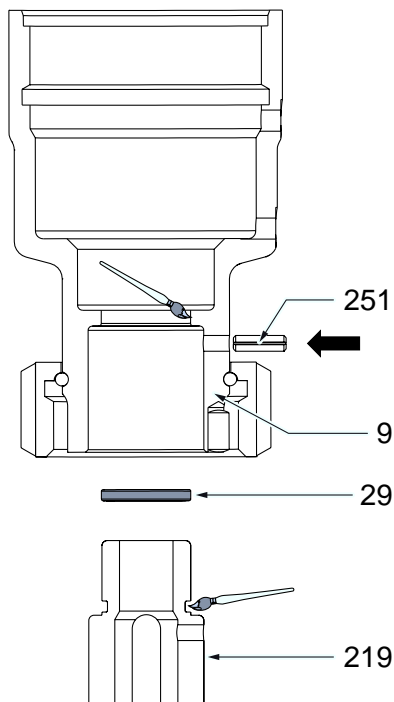

Fig.25: Lantern pneumatic actuator

1. Insert the O-ring (29) into the sleeve (219).
2. Push the sleeve (219) from downwards into the lantern (9).
Align the holes of lantern and sleeve with each other.
3. Drive in the pin (251) until it is flush from the outside.
4. Mount the O-rings (226, 6, 186).

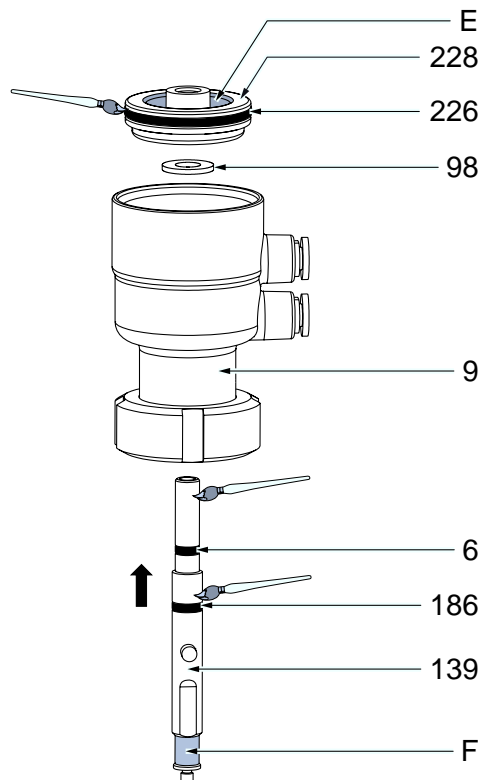

Fig.26: Pneumatic actuator components NC

5. Push the rod (139) from downwards into the lantern (9).
The recess (F) on the rod (139) must point downwards.
6. Push the washer (98) from the top onto the rod (139).
7. Fit the piston (228).
The undercutting (E) of the piston must be open towards the top.

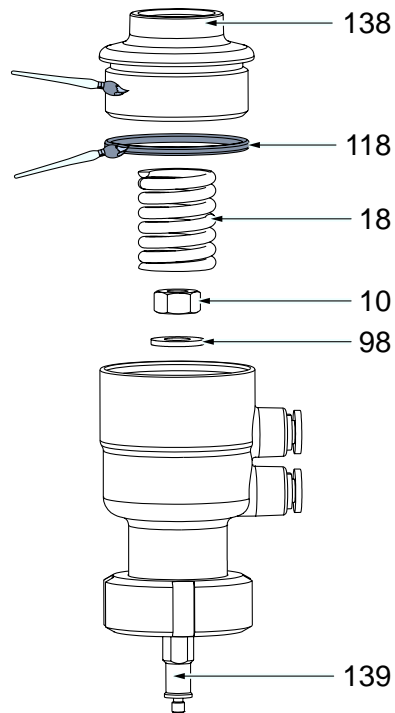

Fig.27: Pneumatic actuator components

8. Push the second washer (98) onto the rod (139). Tighten the hexagon nut (10) using a socket wrench insert.
 9. Push the pressure spring (18) from the top onto the rod (139).
 10. Install O-ring (118) in the cover (138).
 11. Screw on the cover (138) with screwdriver (hexagon socket) AF17.
- Actuator NC –spring-closing has been removed.

Mount the actuator NO–spring-opening

1. Mount the O-rings (226, 6, 186).

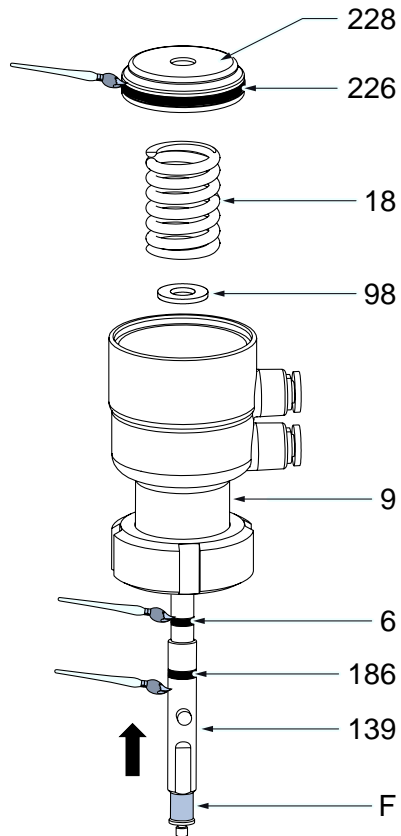

Fig.28: Pneumatic actuator components NO

2. Push the rod (139) from downwards into the lantern (9).
3. Push the washer (98) and pressure spring (18) together with the piston (228) onto the rod (139).
4. Push the second washer (98) from the top onto the rod (139). Tighten the hexagon nut (10) using a socket wrench insert. This loads the pressure spring (18).

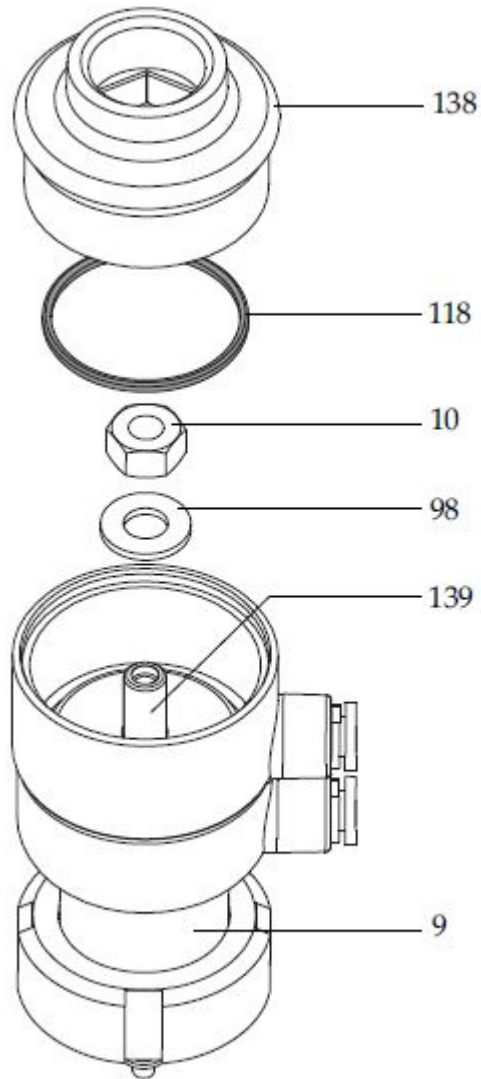

Fig.29: Pneumatic actuator components

5. Install O-ring (118) in the cover (138).
 6. Screw on the cover (138) with screwdriver (hexagon socket) AF17.
- Actuator NO–spring-opening has been mounted.

10.6.2 Assembling the visual position indicator

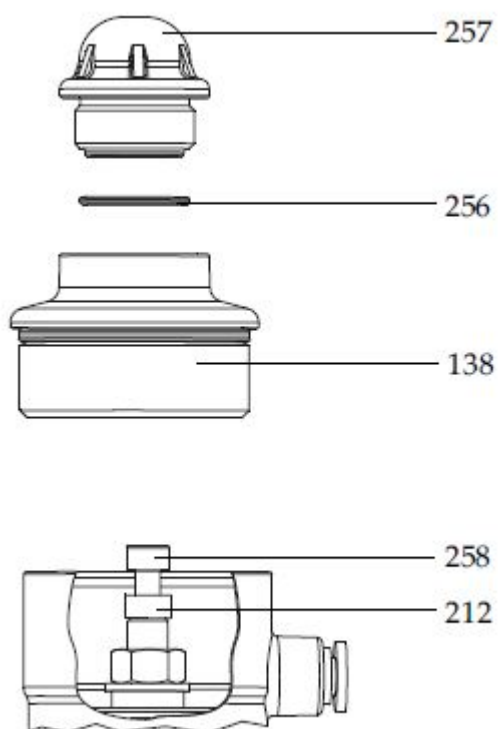

Fig.30: Pneumatic actuator with visual position indicator

Carry out the following steps:

1. Assemble spacer (212) and screw (258).
 2. Install O-ring (256) in the cover (138).
 3. Screw on position indicator cpl. (257).
- Visual position indicator has been assembled.

10.6.3 Installing the control top T.VIS V-1 / P-1

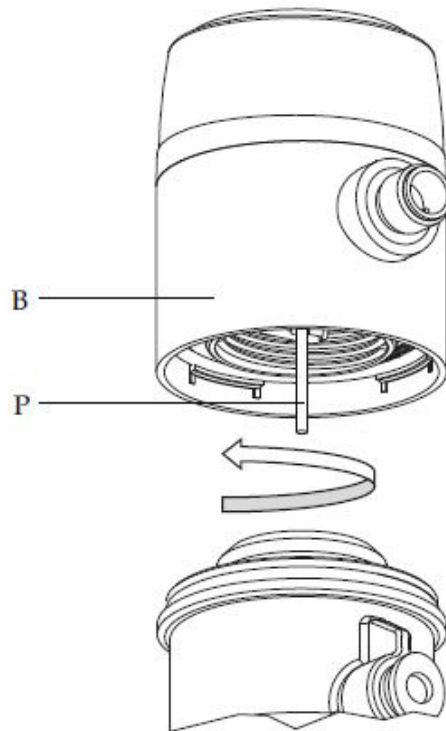

Fig.31: Control top T.VIS V-1

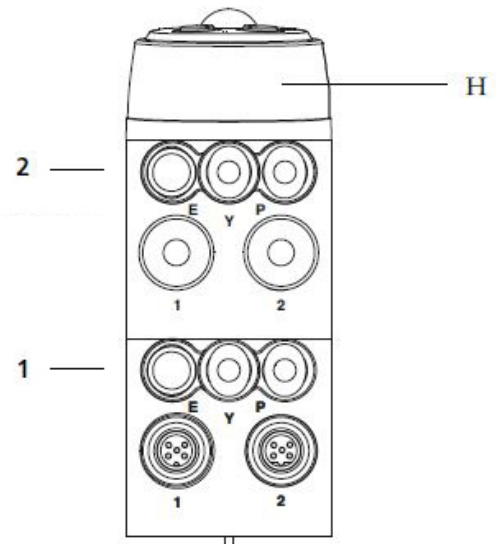

Fig.32: Control top T.VIS P-1 attachment 1 and +2

Notice

The potentiometer spindle (P) is a sensitive component

Damage to potentiometer spindle (P)

- Handle potentiometer spindle (P) carefully

Carry out the following steps:

1. Put on the control top (B) and turn to the right (in the direction of the arrow) until the stop is reached.
 2. Remove electrical and pneumatic connections from the control top (B).
- Control top T.VIS V-1/P-1 has been installed.

10.6.4 Mounting the bellows

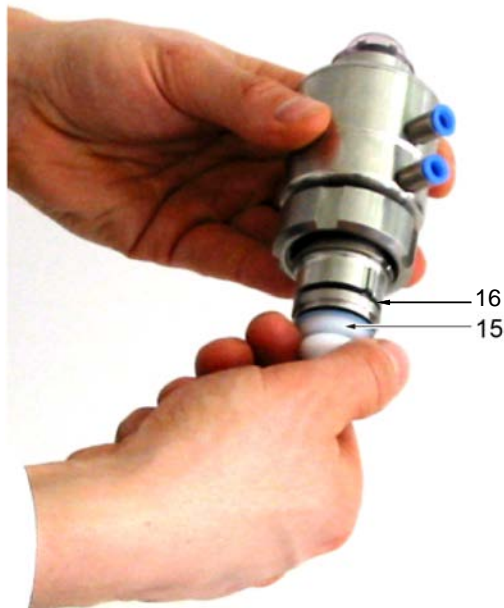

Fig.33

Warning!

Risk of injury by spring force being released on valves with spring-opened actuation (NO) and spring-closing actuation (NC)

You can sustain serious injuries to your fingers when you put your hand into the valve housing.

- ▶ Do not put your hand into the valve housing.

Warning!

In the case of a removed valve insert, (NC) and (NO), there is a risk of injury at point (16).

There is a risk of crushing or clamping.

- ▶ Do not reach into the gap at point (16)!

Notice

Sensitive valve parts

Damage to the valve parts can result in leakage problems and malfunction.

- ▶ Protect the valve parts against impact stress.

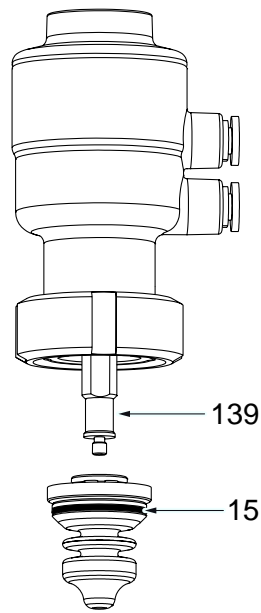

Fig.34

Carry out the following steps:

1. Install bellows (15) on valve disk (139).
→ This completes installation of the bellows.

10.6.5 Installing the valve insert

Prerequisite

- No solenoid valve must be actuated electrically or manually.
- The pneumatic and electrical connections on the plant side can remain on the control top.

Spring-closing valve NC

Carry out the following steps:

 **Warning!**

Spring tension in the valve

There is the risk of injury due to incorrectly screwed on cap nut (252) when the valve is vented as the spring tension that is released suddenly lifts the actuator.

- ▶ Ensure that the cap nut has been assembled correctly before venting.
-

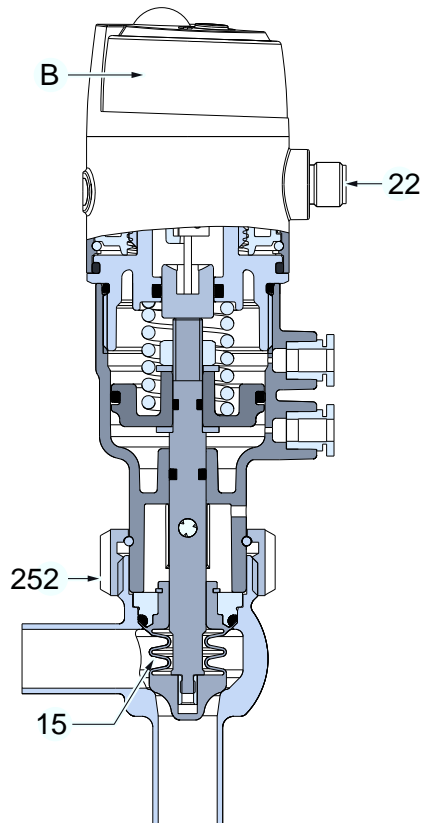

Fig.35: Install valves NC

1. Place the control top (B) on the valve.
 2. Pressurize the valve at the connection with compressed air, max. 8 bar.
→ The bellows (15) are raised.
 3. Guide the valve insert completely into the housing.
! Do not hit the valve parts against the housing.
 4. Tighten the cap nut (252) by hand.
! Pay attention to torques.
 5. Vent the actuator.
→ The bellows (15) are lowered.
- Done.

Spring-opening valve NO

1. Guide the valve insert completely into the housing.
! Do not hit the valve parts against the housing.
 2. Tighten the cap nut with torque wrench.
! Pay attention to torques.
 3. Place the control top (B) on the valve.
→ The valve seat has been installed.
- Done.

10.6.6 Checking the function

Checking the valve stroke

Carry out the following steps:

1. Actuate the valve with compressed air.
 2. Check the valve stroke according to table "valve stroke" (Page 68).
- Stroke has been checked.

Strokes depending on size

Valve stroke	
Valve size	Valve stroke [mm]
DN10	2
DN15	4
DN20	5
DN25	5
DN32	7
OD 0.5"	2
OD 0.75"	4
OD 1"	4.5
ISO 13.5	2
ISO 17.2	3
ISO 21.3	3
ISO 26.9	5
ISO 33.7	7

11 Alarms

11.1 Malfunctions and remedies

Notice

Warning of damage to property/loss of product

Ignoring malfunctions may cause considerable damage to property and loss of product. The safe operation of the valve in the event of a malfunction can no longer be taken for granted and in the worst case can result in a loss of sterility in the process.

- ▶ Make sure that malfunctions are quickly identified and promptly fixed.

In the event of malfunctions immediately deactivate the valve and secure it against inadvertent reactivation. Malfunctions may only be remedied by qualified staff, who must observe the safety precautions.

Fault	Cause	Remedy
Valve does not work	Fault in the controller	Check the system configuration
	No compressed air or compressed air too low	Check the compressed air supply Check air hoses for free passage and air tightness
	Fault in the electrical system	Check actuation / external controller and routing of electrical lines
	Actuator leaking	Replacing seals
Valve does not close tight	Dirt/foreign material between valve seat and bellows	Clean valve housing and bellows
	Seat area in the housing damaged	Replace the housing
	PTFE bellows defective	Replace PTFE bellows
Valve closes too slowly	O-rings in the actuator and control top are dry (friction losses)	Grease O-rings
Medium is leaking from the leakage holes of the lantern	Bellows are not fitted correctly or the sealing lip at the bellows is damaged	Fit the bellows correctly or replace if damaged
The maximum stroke is not reached when the valve is actuated pneumatically	Leakage in the actuator.	Check the sealing surfaces in the actuator for damage.
		Replace the seals
Valve feedback not correct.	The feedback unit is not fitted correctly	Check that the feedback unit has been fitted correctly.

Alarms

Fault	Cause	Remedy
	The proximity switch is not in the correct position or is defective	Check the proximity switch position and readjust if necessary
	Fault in the power supply	Check the wiring
Actuator is filling with water	Unfavourable installation position	Align air connections downwards, if possible
	Unfavourable effect of the exterior cleaning of the plant	For vertical valve installation: Align air connections away from the cleaning direction, if possible

12 Decommissioning

12.1 Safety instructions

For shutting down, the following principles apply:

- Switch off the compressed air.
- Switch off the component with the main switch.
- Padlock the main switch (if fitted) in the off position to prevent it from being switched back on. The key to the padlock must be deposited with the person responsible until the machine is restarted.
- For longer periods of standstill, observe the storage conditions, see Chapter 4, Page 23.

12.2 Disposal

12.2.1 General notes

Dispose of the component in an environmentally safe manner. Observe the statutory waste disposal regulations applicable at the place of installation.

The component consists of the following materials:

- Metals
- Synthetic materials
- Electronic parts
- Lubricants containing oil and grease

Separate the different materials and dispose of them correctly sorted. Also observe the instructions regarding disposal in the operating instructions for the individual components.

13 Dimension sheet - VESTA sterile valves tank bottom valve H_A/T/H

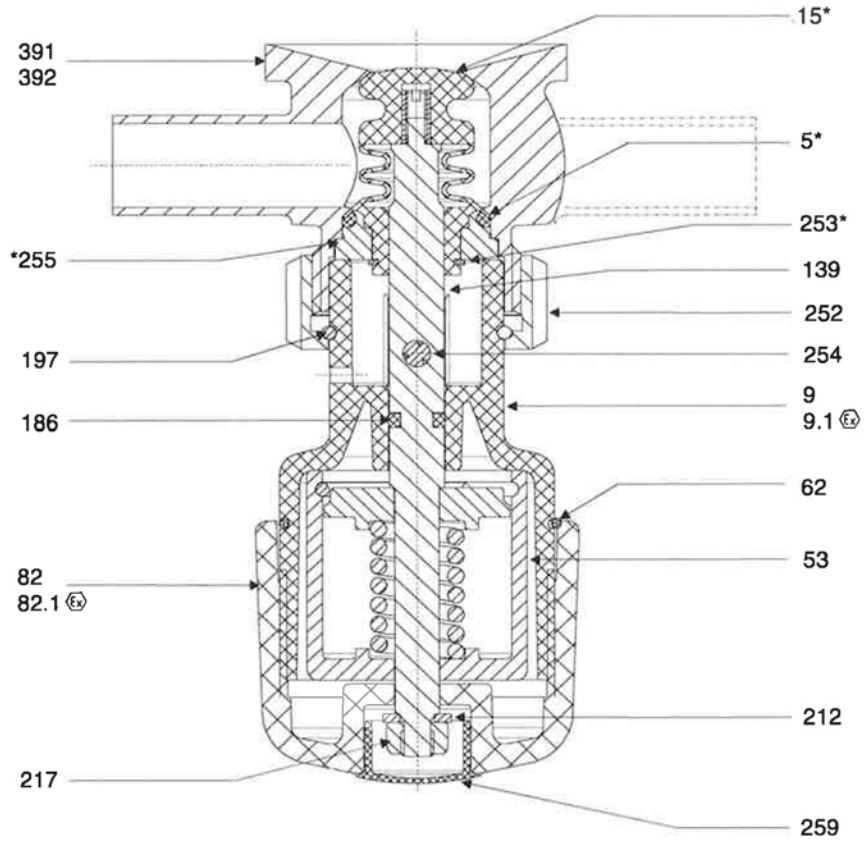

Fig.36: Manual actuator H_A/H with housing HLA/T and HTA/T

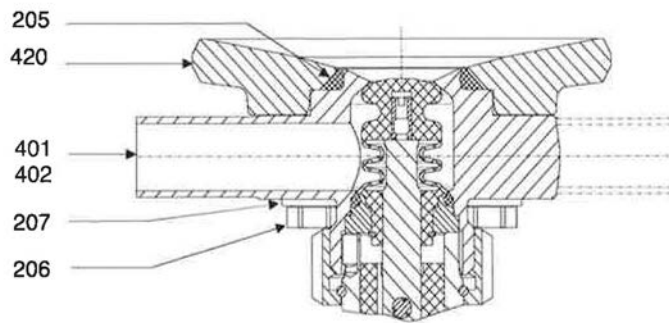

Fig.37: Manual actuator H_A/H with housing connection HLA/T/F and HTA/T/F

Dimension sheet - VESTA sterile valves tank bottom valve H_A/T/H

Item	Designation	Material	DN 10	DN 15	DN 20	DN 25	DN 32
5*	O-ring	EPDM	930-860	930-860	930-862	930-861	930-861
9	Lantern H_A/H	PPSGV40	221-001054	221-001054	221-001055	221-001056	221-001056
9.1	Lantern H_A/H Ex	Tedur L 9400-3.2	221-002964	221-002964	--	--	--
15*	Bellows H_A	TFM1705/ 1.4301	221-001429	221-001429	221-001428	221-001427	221-001427
*	Bellows H_A cpl. comprising pos. 5, 15, 253 and 255		221-002056	221-002056	221-002057	221-002058	221-002058
53	Spring package H_A/H	3.2315.T6	221-001074	221-001074	221-001092	221-001094	221-001094
62	O-ring	MVQ	930-917	930-917	930-917	930-917	930-917
82	Handwheel H_A/H	PP/black	221-001058	221-001058	221-001058	221-001058	221-001058
82.1	Handwheel H_A/H Ex	Tedur L 9400-3.2	221-002965	221-002965	--	--	--
139	Rod H_A8/H	1.4301	221-001079	221-001079	221-001091	221-001093	221-001093
186	O-ring	HNBR	930-921	930-921	930-803	930-922	930-922
197	Snap ring	1.4310	917-172	917-172	917-184	917-173	917-173
205	O-ring	EPDM	930-558	930-558	930-143	930-143	930-143
206	Hex head screw	A2-70	901-054	901-054	901-061	901-305	901-305
207	Ring	A-8.4	921-014	921-014	921-014	921-014	921-014
212	Ring	A2	921-135	921-135	921-135	921-135	921-135
217	Hexagon nut	A2	910-015	910-015	910-015	910-015	910-015
252	Cap nut H_A	1.4301	221-000898	221-000898	221-000992	221-000938	221-000938
253*	Retaining ring	1.4310	917-182	917-182	917-116	917-183	917-183
254	Grooved pin	1.4301	915-040	915-040	915-042	915-041	915-041
255*	Thrust washer H_A	1.4301	221-000897	221-000897	221-000990	221-000937	221-000937
259	Round plug	PE-LD	922-310	922-310	922-310	922-310	922-310
391	Housing HLA/T	1.4435	221-001958	221-001954	221-001963	221-001966	221-003347
392	Housing HTA/T	1.4435	221-002045	221-002048	221-002051	221-002054	221-003348
401	Housing HLA/T/F	1.4435	221-001909	221-001637	221-001915	221-001917	221-003371
402	Housing HTA/T/F	1.4435	221-002018	221-002025	221-002031	221-002042	221-003372
420	Housing H_A	1.4435	221-001631	221-001631	221-001633	221-001633	22-001633

Dimension sheet - VESTA sterile valves tank bottom valve H_A/T/H

Item	Designation	Material	0.5" OD	0.75" OD	1" OD
5*	O-ring	EPDM	930-860	930-860	930-862
9	Lantern H_A/H	PPSGV40	221-001054	221-001054	221-001055
9.1	Lantern H_A/H	Tedur L 9400-3.2	221-002964	221-002964	--
15*	Bellows H_A	TFM1705/ 1.4301	221-001429	221-001429	221-001428
*	Bellows H_A cpl. comprising pos. 5, 15, 253 and 255		221-002056	221-002056	221-002057
53	Spring package H_A/H	3.2315.T6	221-001074	221-001074	221-001092
62	O-ring	MVQ	930-917	930-917	930-917
82	Handwheel H_A/H	PP/black	221-001058	221-001058	221-001058
82.1	Handwheel H_A/H	Tedur L 9400-3.2	221-002965	221-002965	--
139	Rod H_A8/H	1.4301	221-001079	221-001079	221-001091
186	O-ring	HNBR	930-921	930-921	930-803
197	Snap ring	1.4310	917-172	917-172	917-184
205	O-ring	EPDM	930-558	930-558	930-143
206	Hex head screw	A2-70	901-054	901-054	901-061
207	Ring	A-8.4	921-014	921-014	921-014
212	Ring	A2	921-135	921-135	921-135
217	Hexagon nut	A2	910-015	910-015	910-015
252	Cap nut H_A	1.4301	221-000898	221-000898	221-000992
253*	Retaining ring	1.4310	917-182	917-182	917-116
254	Grooved pin	1.4301	915-040	915-040	915-042
255*	Thrust washer H_A	1.4301	221-000897	221-000897	221-000990
259	Round plug	PE-LD	922-310	922-310	922-310
391	Housing HLA/T	1.4435	221-001959	221-001960	221-001962
392	Housing HTA/T	1.4435	221-002044	221-002049	221-002052
401	Housing HLA/T/F	1.4435	221-001908	221-001912	221-001916
402	Housing HTA/T/F	1.4435	221-002016	221-002027	221-002033
420	Housing H_A	1.4435	221-001631	221-001631	221-001633

Dimension sheet - VESTA sterile valves tank bottom valve H_A/T/H

Item	Designation	Material	ISO 13.5	ISO 17.2	ISO 21.3	ISO 26.9	ISO 33.7
5*	O-ring	EPDM	930-860	930-860	930-862	930-861	930-861
9	Lantern H_A/H	PPSGV40	221-001054	221-001054	221-001055	221-001056	221-001056
9.1	Lantern H_A/H	Tedur L 9400-3.2	221-002964	221-002964	--	--	--
15*	Bellows H_A	TFM1705/ 1.4301	221-001429	221-001429	221-001428	221-001427	221-001427
*	Bellows H_A cpl. comprising pos. 5, 15, 253 and 255		221-002056	221-002056	221-002057	221-002058	221-002058
53	Spring package H_A/H	3.2315.T6	221-001074	221-001074	221-001092	221-001094	221-001094
62	O-ring	MVQ	930-917	930-917	930-917	930-917	930-917
82	Handwheel H_A/H	PP/black	221-001058	221-001058	221-001058	221-001058	221-001058
82.1	Handwheel H_A/H	Tedur L 9400-3.2	221-002965	221-002965	--	--	--
139	Rod H_A8/H	1.4301	221-001079	221-001079	221-001091	221-001093	221-001093
186	O-ring	HNBR	930-921	930-921	930-803	930-922	930-922
197	Snap ring	1.4310	917-172	917-172	917-184	917-173	917-173
205	O-ring	EPDM	930-558	930-558	930-143	930-143	930-143
206	Hex head screw	A2-70	901-054	901-054	901-061	901-305	901-305
207	Ring	A-8.4	921-014	921-014	921-014	921-014	921-014
212	Ring	A2	921-135	921-135	921-135	921-135	921-135
217	Hexagon nut	A2	910-015	910-015	910-015	910-015	910-015
252	Cap nut H_A	1.4301	221-000898	221-000898	221-000992	221-000938	221-000938
253*	Retaining ring	1.4310	917-182	917-182	917-116	917-183	917-183
254	Grooved pin	1.4301	915-040	915-040	915-042	915-041	915-041
255*	Thrust washer H_A	1.4301	221-000897	221-000897	221-000990	221-000937	221-000937
259	Round plug	PE-LD	922-310	922-310	922-310	922-310	922-310
391	Housing HLA/T	1.4435	221-001958	221-001954	221-001963	221-001966	221-003347
392	Housing HTA/T	1.4435	221-002045	221-002048	221-002051	221-002054	221-003348
401	Housing HLA/T/F	1.4435	221-001909	221-001637	221-001915	221-001917	221-003371
402	Housing HTA/T/F	1.4435	221-002018	221-002025	221-002031	221-002042	221-003372
420	Housing H_A	1.4435	221-001631	221-001631	221-001633	221-001633	22-001633
392	Housing HTA/T	1.4435	221-002045	221-002048	221-002051	221-002054	221-003348
401	Housing HLA/T/F	1.4435	221-001909	221-001637	221-001915	221-001917	221-003371
402	Housing HTA/T/F	1.4435	221-002018	221-002025	221-002031	221-002042	221-003372
420	Housing H_A	1.4435	221-001631	221-001631	221-001633	221-001633	221-001633

14 Spare parts list - VESTA sterile valves tank bottom valve H_A/T

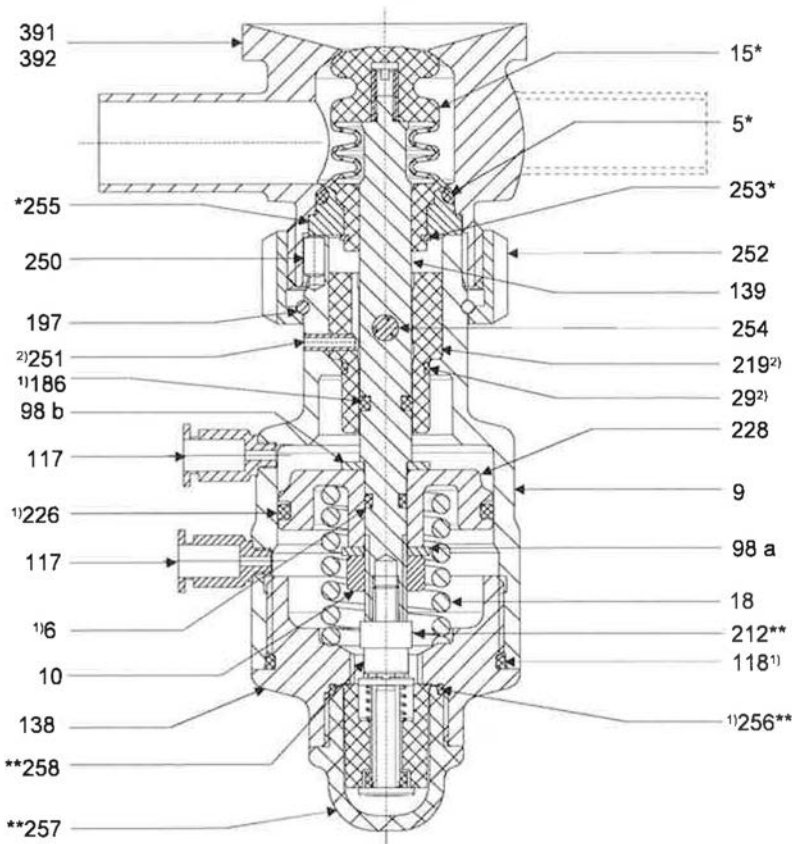

Fig.38: Pneumatic actuator H_A/M with housing HLA/T and HTA/T - metal model

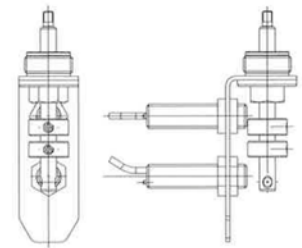

Fig.39: Mounting for proximity switch H_A
Accessories

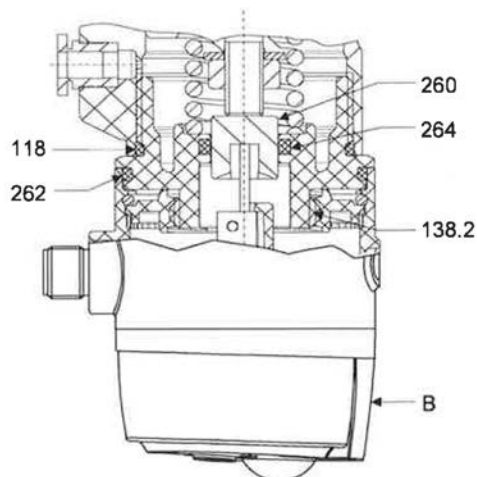

Fig.40: Pneumatic actuator H_A/TV for control module T.VIS V-1/P-1

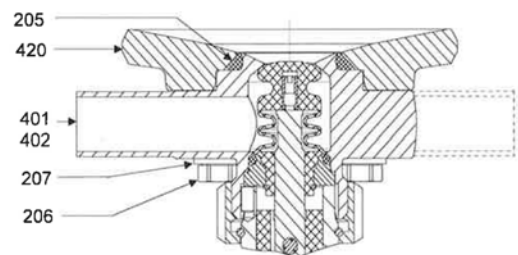

Fig.41: Manual actuator H_A/H with housing connection HLA/T/F and HTA/T/F- metal version

The non-positioned spare parts are listed in pneumatic actuator H_A.

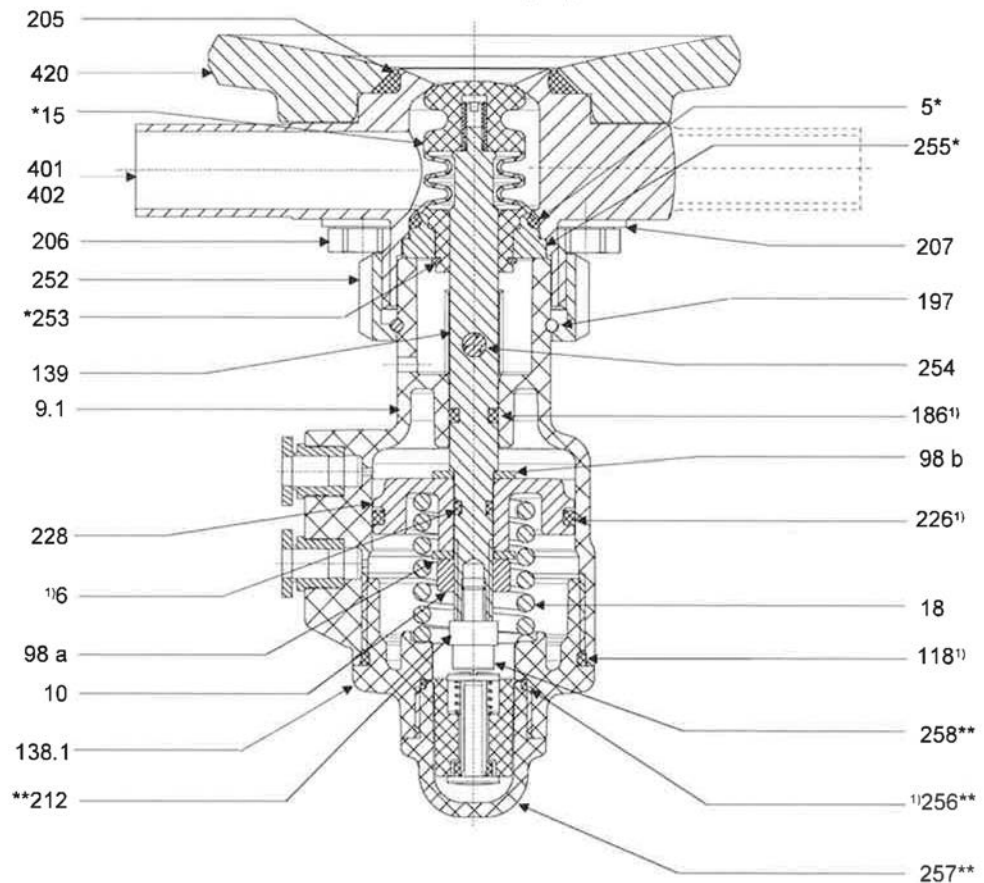

Fig.42: Pneumatic actuator H_A with housing connection HLA/T/F and HTA/T/F

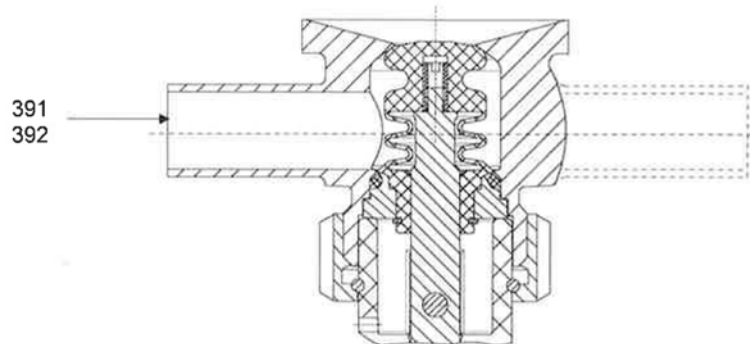

Fig.43: Pneumatic actuator H_A with housing HLA/T and HTA/T

Spare parts list - VESTA sterile valves tank bottom valve H_A/T

Item	Designation	Material	DN 10	DN 15	DN 20	DN 25	DN 32
Seal set H_A 1)			221-003887	221-003887	221-003888	221-003889	221-003889
Seal set H_AM 1)+2)			221-003890	221-003890	221-003891	221-003892	221-003892
5*	O-ring	EPDM	930-860	930-860	930-862	930-861	930-861
6 1)	O-ring	FKM	930-683	930-683	930-683	--	--
		NBR	--	--	930-931	930-931	930-931
9	Lantern H_A/M	1.4301	221-001061	221-001061	221-001070	221-001071	221-001071
9.1	Lantern H_A	PPSGV40	221-000900	221-000900	221-000988	221-000911	221-000911
10	Hexagon nut	A2	910-018	910-018	910-026	910-026	910-026
15*	Bellows H_A	TFM1705/ 1.4301	221-001429	221-001429	221-001428	221-001427	221-001427
*	Bellows H_A cpl. comprising pos. 5, 15, 253 and 255		221-002056	221-002056	221-002057	221-002058	221-002058
18	Compression spring	1.4310	931-281	931-281	931-283	931-282	931-282
29 2)	O-ring	HNBR	930-957	930-957	930-866	930-867	930-867
98a	Ring	A2	921-014	921-014	921-018	921-018	921-018
98b	Ring	A2	921-014	921-014	921-018	--	--
117	Screw-in plug connection	Brass, nickel-plated	933-977	933-977	933-977	933-977	933-977
118 1)	O-ring	NBR	930-479	930-479	930-073	930-082	930-082
138	Cover H_A/M	1.4301	221-001062	221-001062	221-001063	221-001064	221-001064
138.1	Cover H_A	PPSGV40	221-000881	221-000881	221-000982	221-000882	221-000882
139	Rod H_A	1.4301	221-000895	221-000895	221-000991	221-000917	221-000917
186 1)	O-ring	HNBR	930-921	930-921	930-803	930-922	930-922
197	Snap ring	1.4310	917-172	917-172	917-184	917-173	917-173
205	O-ring	EPDM	930-1083	930-1083	930-1071	930-1071	930-1071
206	Hex head screw	A2-70	901-054	901-054	901-061	901-305	901-305
207	Ring	A-8.4	921-014	921-014	921-014	921-014	921-014
212**	Space piece	PA	221-001260	221-001260	221-001261	221-001262	221-001262
219 2)	Sleeve H_A/M	PVDF	221-001060	221-001060	221-001073	221-001072	221-001072
226 1)	O-ring	NBR	930-050	930-050	930-065	930-729	930-729
228	Piston H_A	3.2315.T6	221-001127	221-001127	221-001089	221-001088	221-001088
250	Straight pin	A4	915-078	915-078	915-078	915-078	915-078
251 2)	Spring pin	1.4310	925-094	925-094	925-094	925-094	925-094
252	Cap nut H_A	1.4301	221-000898	221-000898	221-000992	221-000938	221-000938
253*	Retaining ring	1.4310	917-182	917-182	917-116	917-183	917-183
254	Grooved pin	1.4301	915-040	915-040	915-042	915-041	915-041
255*	Thrust washer H_A	1.4301	221-000897	221-000897	221-000990	221-000937	221-000937
256** 1)	O-ring	HNBR	930-866	930-866	930-866	930-866	930-866
257**	Position indicator H_A	PA6	221-001057	221-001057	221-001057	221-001057	221-001057
**	Position indicator H_A cpl. comprising pos. 212, 256, 257 and 258		221-001298	221-001298	221-001299	221-001300	221-001300
258**	Cylinder screw with hex socket	A2-70	902-114	902-114	902-093	902-093	902-093
391	Housing HLA/T	1.4435	221-001958	221-001954	221-001963	221-001966	221-003347

Spare parts list - VESTA sterile valves tank bottom valve H_A/T

Item	Designation	Material	DN 10	DN 15	DN 20	DN 25	DN 32
392	Housing HTA/T	1.4435	221-002045	221-002048	221-002051	221-002054	221-003348
401	Housing HLA/T/F	1.4435	221-001909	221-001637	221-001915	221-001917	221-003371
402	Housing HTA/T/F	1.4435	221-002018	221-002025	221-002031	221-002042	221-003372
420	Housing H_A	1.4435	221-001631	221-001631	221-001633	221-001633	221-001633
1) Pos. 6, 118, 186, (219), 226 and (251) 256 are included in the seal set							

Accessories							
Item	Designation	Material					
Mounting for proximity switch H_A		1.4301	221-001806				
see spare parts list for mounting for proximity switch H_A / 221ELI003921							
B	Control top T.VIS® V-1/P-1	see spare parts list for control top T.VIS® V-1/P-1 / 221ELI004766					
Pneumatic actuator H_A/TV for control module T.VIS® V-1/P-1							
118	O-ring	NBR	930-479	930-479	930-073	930-082	930-082
138.2	Cover T.VIS/V-1	PPSGV40	221-002303	221-002303	221-002304	221-002305	221-002305
138.3	Cover T.VIS/V-1	1.4305	221-002173	221-002173	221-002174	221-002175	221-002175
260	Adapter T.VIS/V-1	1.4301	221-002253	221-002253	221-002253	221-002253	221-002253
262	O-ring	NBR	930-903	930-903	930-903	930-903	930-903
264	O-ring	NBR	930-012	930-012	930-012	930-012	930-012

Spare parts list - VESTA sterile valves tank bottom valve H_A/T

Item	Designation	Material	0.5" OD	0.75" OD	1" OD
Seal set H_A 1)			221-003887	221-003887	221-003888
Seal set H_AM 1)+2)			221-003890	221-003890	221-003891
5*	O-ring	EPDM	930-860	930-860	930-862
6 1)	O-ring	FKM	930-683	930-683	930-683
		NBR	--	--	930-931
9	Lantern H_A/M	1.4301	221-001061	221-001061	221-001070
9.1	Lantern H_A	PPSGV40	221-000900	221-000900	221-000988
10	Hexagon nut	A2	910-018	910-018	910-026
15*	Bellows H_A	TFM1705/ 1.4301	221-001429	221-001429	221-001428
*	Bellows H_A cpl. comprising pos. 5, 15, 253 and 255		221-002056	221-002056	221-002057
18	Compression spring	1.4310	931-281	931-281	931-283
29 2)	O-ring	HNBR	930-957	930-957	930-866
98a	Ring	A2	921-014	921-014	921-018
98b	Ring	A2	921-014	921-014	921-018
117	Screw-in plug connection	Brass, nickel-plated	933-977	933-977	933-977
118 1)	O-ring	NBR	930-479	930-479	930-073
138	Cover H_A/M	1.4301	221-001062	221-001062	221-001063
138.1	Cover H_A	PPSGV40	221-000881	221-000881	221-000982
139	Rod H_A	1.4301	221-000895	221-000895	221-000991
186 1)	O-ring	HNBR	930-921	930-921	930-803
197	Snap ring	1.4310	917-172	917-172	917-184
205	O-ring	EPDM	930-1083	930-1083	930-1071
206	Hex head screw	A2-70	901-054	901-054	901-061
207	Ring	A-8.4	921-014	921-014	921-014
212**	Space piece	PA	221-001260	221-001260	221-001261
219 2)	Sleeve H_A/M	PVDF	221-001060	221-001060	221-001073
226 1)	O-ring	NBR	930-050	930-050	930-065
228	Piston H_A	3.2315.T6	221-001127	221-001127	221-001089
250	Straight pin	A4	915-078	915-078	915-078
251 2)	Spring pin	1.4310	925-094	925-094	925-094
252	Cap nut H_A	1.4301	221-000898	221-000898	221-000992
253*	Retaining ring	1.4310	917-182	917-182	917-116
254	Grooved pin	1.4301	915-040	915-040	915-042
255*	Thrust washer H_A	1.4301	221-000897	221-000897	221-000990
256** 1)	O-ring	HNBR	930-866	930-866	930-866
257**	Position indicator H_A	PA6	221-001057	221-001057	221-001057
**	Position indicator H_A cpl. comprising pos. 212, 256, 257 and 258		221-001298	221-001298	221-001299
258**	Cylinder screw with hex socket	A2-70	902-114	902-114	902-093
391	Housing HLA/T	1.4435	221-001959	221-001960	221-001962
392	Housing HTA/T	1.4435	221-002044	221-002049	221-002052
401	Housing HLA/T/F	1.4435	221-001908	221-001912	221-001916

Spare parts list - VESTA sterile valves tank bottom valve H_A/T

Item	Designation	Material	0.5" OD	0.75" OD	1" OD
402	Housing HTA/T/F	1.4435	221-002016	221-002027	221-002033
420	Housing H_A	1.4435	221-001631	221-001631	221-001633

Accessories					
Item	Designation	Material			
Mounting for proximity switch H_A		1.4301	221-001806		
		see spare parts list for mounting for proximity switch H_A / 221ELI003921			
B	Control top T.VIS® V-1/P-1	see spare parts list for control top T.VIS® V-1/P-1 / 221ELI004766			
Pneumatic actuator H_A/TV for control module T.VIS® V-1/P-1					
118	O-ring	NBR	930-479	930-479	930-073
138.2	Cover T.VIS/V-1	PPSGV40	221-002303	221-002303	221-002304
138.3	Cover T.VIS/V-1	1.4305	221-002173	221-002173	221-002174
260	Adapter T.VIS/V-1	1.4301	221-002253	221-002253	221-002253
262	O-ring	NBR	930-903	930-903	930-903
264	O-ring	NBR	930-012	930-012	930-012

Spare parts list - VESTA sterile valves tank bottom valve H_A/T

Item	Designation	Material	ISO 13.5	ISO 17.2	ISO 21.3	ISO 26.9	ISO 33.7
Seal set H_A 1)			221-003887	221-003887	221-003888	221-003889	221-003889
Seal set H_AM 1)+2)			221-003890	221-003890	221-003891	221-003892	221-003892
5*	O-ring	EPDM	930-860	930-860	930-862	930-861	930-861
6 1)	O-ring	FKM	930-683	930-683	930-683	--	--
		NBR	--	--	930-931	930-931	930-931
9	Lantern H_A/M	1.4301	221-001061	221-001061	221-001070	221-001071	221-001071
9.1	Lantern H_A	PPSGV40	221-000900	221-000900	221-000988	221-000911	221-000911
10	Hexagon nut	A2	910-018	910-018	910-026	910-026	910-026
15*	Bellows H_A	TFM1705/ 1.4301	221-001429	221-001429	221-001428	221-001427	221-001427
*	Bellows H_A cpl. comprising pos. 5, 15, 253 and 255		221-002056	221-002056	221-002057	221-002058	221-002058
18	Compression spring	1.4310	931-281	931-281	931-283	931-283	931-282
29 2)	O-ring	HNBR	930-957	930-957	930-866	930-866	930-867
98a	Ring	A2	921-014	921-014	921-018	921-018	921-018
98b	Ring	A2	921-014	921-014	921-018	921-018	--
117	Screw-in plug connection	Brass, nickel-plated	933-977	933-977	933-977	933-977	933-977
118 1)	O-ring	NBR	930-479	930-479	930-073	930-082	930-082
138	Cover H_A/M	1.4301	221-001062	221-001062	221-001063	221-001063	221-001064
138.1	Cover H_A	PPSGV40	221-000881	221-000881	221-000982	221-000982	221-000882
139	Rod H_A	1.4301	221-000895	221-000895	221-000991	221-000991	221-000917
186 1)	O-ring	HNBR	930-921	930-921	930-803	930-803	930-922
197	Snap ring	1.4310	917-172	917-172	917-184	917-184	917-173
205	O-ring	EPDM	930-1083	930-1083	930-1071	930-1071	930-1071
206	Hex head screw	A2-70	901-054	901-054	901-061	901-061	901-305
207	Ring	A-8.4	921-014	921-014	921-014	921-014	921-014
212**	Space piece	PA	221-001260	221-001260	221-001261	221-001261	221-001262
219 2)	Sleeve H_A/M	PVDF	221-001060	221-001060	221-001073	221-001073	221-001072
226 1)	O-ring	NBR	930-050	930-050	930-065	930-065	930-729
228	Piston H_A	3.2315.T6	221-001127	221-001127	221-001089	221-001089	221-001088
250	Straight pin	A4	915-078	915-078	915-078	915-078	915-078
251 2)	Spring pin	1.4310	925-094	925-094	925-094	925-094	925-094
252	Cap nut H_A	1.4301	221-000898	221-000898	221-000992	221-000992	221-000938
253*	Retaining ring	1.4310	917-182	917-182	917-116	917-116	917-183
254	Grooved pin	1.4301	915-040	915-040	915-042	915-042	915-041
255*	Thrust washer H_A	1.4301	221-000897	221-000897	221-000990	221-000990	221-000937
256** 1)	O-ring	HNBR	930-866	930-866	930-866	930-866	930-866
257**	Position indicator H_A	PA6	221-001057	221-001057	221-001057	221-001057	221-001057
**	Position indicator H_A cpl. comprising pos. 212, 256, 257 and 258		221-001298	221-001298	221-001299	221-001299	221-001300
258**	Cylinder screw with hex socket	A2-70	902-114	902-114	902-093	902-093	902-093
391	Housing HLA/T	1.4435	221-001958	221-001954	221-001963	221-001966	221-003347

Spare parts list - VESTA sterile valves tank bottom valve H_A/T

Item	Designation	Material	ISO 13.5	ISO 17.2	ISO 21.3	ISO 26.9	ISO 33.7
392	Housing HTA/T	1.4435	221-002045	221-002048	221-002051	221-002054	221-003348
401	Housing HLA/T/F	1.4435	221-001909	221-001637	221-001915	221-001917	221-003371
402	Housing HTA/T/F	1.4435	221-002018	221-002025	221-002031	221-002042	221-003372
420	Housing H_A	1.4435	221-001631	221-001631	221-001633	221-001633	on request

Accessories							
Item	Designation	Material					
Mounting for proximity switch H_A		1.4301	221-001806				
		see spare parts list for mounting for proximity switch H_A / 221ELI003921					
B	Control top T.VIS® V-1/P-1	see spare parts list for control top T.VIS® V-1/P-1 / 221ELI004766					
Pneumatic actuator H_A/TV for control module T.VIS® V-1/P-1							
118	O-ring	NBR	930-479	930-479	930-073	930-082	930-082
138.2	Cover T.VIS/V-1	PPSGV40	221-002303	221-002303	221-002304	221-002304	221-002305
138.3	Cover T.VIS/V-1	1.4305	221-002173	221-002173	221-002174	221-002174	221-002175
260	Adapter T.VIS/V-1	1.4301	221-002253	221-002253	221-002253	221-002253	221-002253
262	O-ring	NBR	930-903	930-903	930-903	930-903	930-903
264	O-ring	NBR	930-012	930-012	930-012	930-012	930-012

15 Spare parts list -mounting for proximity switch H_A

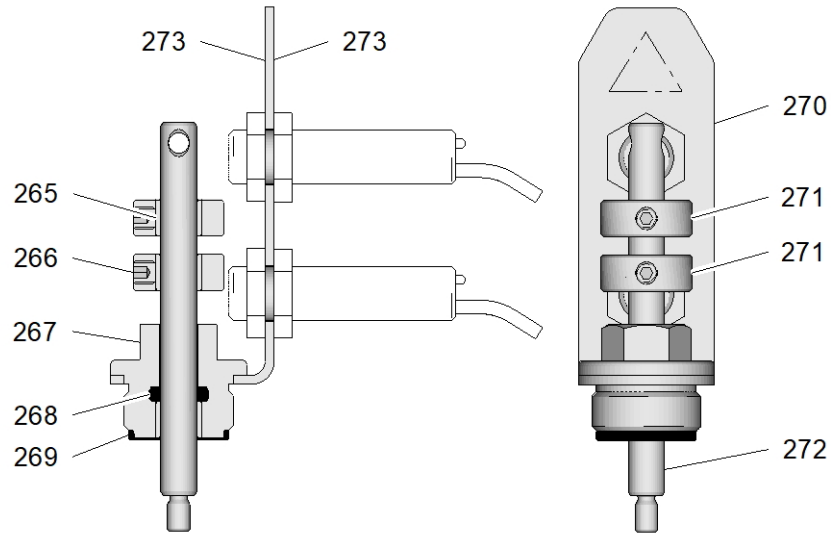

Fig.44

Spare parts list -mounting for proximity switch H_A

Item	Designation	Material	Material no.
	Mounting for proximity switch H_A	1.4301	221-001806
265	Plain bearing	IGLIDUR-G	704-059
266	Set screw	A2-70	914-056
267	Mounting base	1.4301	221-001772
268	O-ring	NBR	930-005
269	O-ring	HNBR	930-866
270	Retaining plate H_A	1.4301	221-001769
271	Switch ring H_A	1.4301	221-001774
272	Switch rod H_A	1.4301	221-001770
273	Triangular sign	PCV film	700-130

16 Spare parts list - welding jig H_A/T and T_A

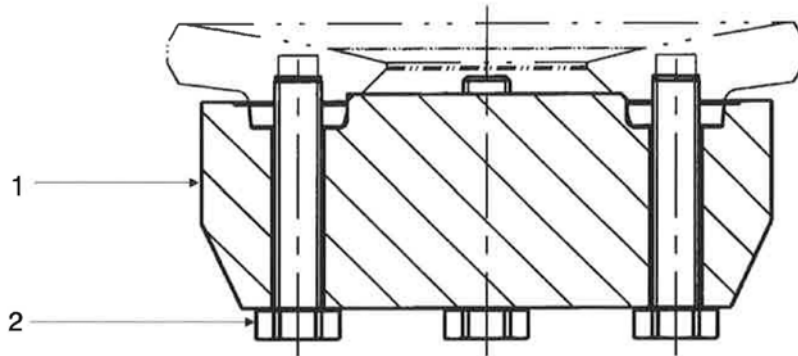

Fig.45

Item	Designation	Material	Material no.				
			DN 15	DN 25	DN 50	DN 80	DN 100
Welding jig H_A/T cpl.			229-103.68	229-103.70	--	--	--
Welding jig H_A/T cpl.			--	--	229-103.54	229-103.55	229-103.56
1	Welding device	EN AW-6082 T6	229-103.67	229-103.69	229-103.50	229-103.51	229-103.52
2	Hex head screw	A2	901-061	901-061	901-321	901-153	901-158

Use of the welding jig	for VESTA tank bottom valves H_A/T
DN 15	DN 10; DN 15; 0.5" OD; 0.75" OD; ISO 13.5; ISO 17.2
DN 25	DN 20; DN 25; 1" OD; ISO 21.3; ISO 26.9; ISO 33.7
Use of the welding jig	For STERICOM Aseptik tank bottom valves T_A
DN 50	DN 40; DN 50; 1.5" OD, 2" OD
DN 80	DN 65; DN 80; 2.5" OD, 3" OD
DN 100	DN 100; 4" OD
Attention! When welding in the housing connections H_A/T and T_A pay attention to welding instructions 221RLI006235.	

17 Dimension sheet - VESTA sterile valves tank bottom valve H_A/T

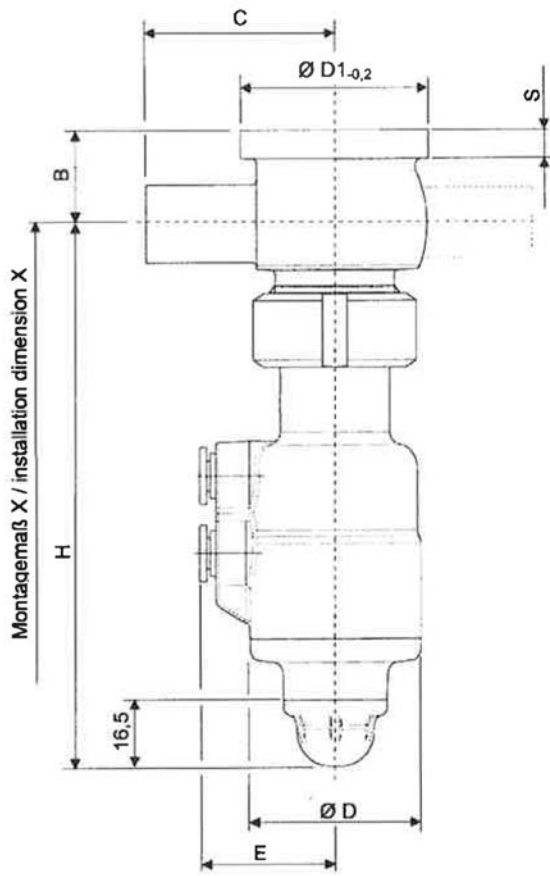

Fig.46: VESTA tank bottom valve H_A/T and H_A/T/M with housing for welding

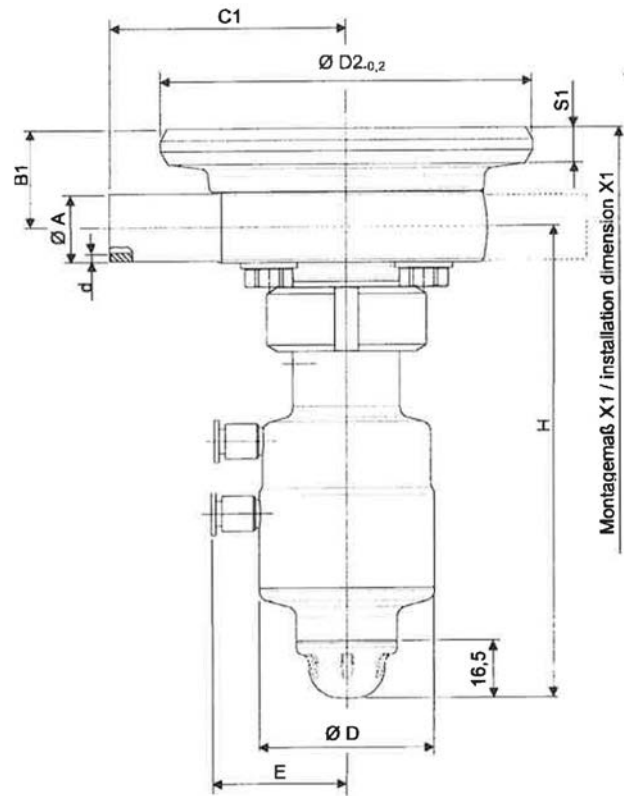

Fig.47: VESTA tank bottom valve H_A/T/F and H_A/T/F/M with housing for flanging

Dimension sheet - VESTA sterile valves tank bottom valve H_A/T

Dimension		DN10	DN15	DN20	DN25	0.5"OD	0.75"OD	1" OD	ISO 13.5	ISO 17.2	ISO 21.3	ISO 26.9	ISO 33.7
B	[mm]	26	23	29	35	26.3	23	28	25.8	24	30	27	33
B1	[mm]	31	28	34	37	31.3	28	33	31	29	35	32	35
C	[mm]	55	55	65	70	55	55	65	55	55	65	65	70
C1	[mm]	70	70	85	85	70	70	85	70	70	85	85	85
S	[mm]	40	40	47	53	40	40	47	40	40	47	47	53
H	[mm]	131	134	144	161	131	134	145	131	133	143	146	163
Ø A	[mm]	13	19	23	29	12.7	19.05	25.4	13.5	17.2	21.3	26.9	33.7
Ø D	[mm]	50	50	65	77	50	50	65	50	50	65	65	77
Ø D1-0.2	[mm]	54.9	54.9	79.9	84.9	54.9	54.9	79.9	54.9	54.9	79.9	79.9	84.9
Ø D-0.2	[mm]	110	110	130	130	110	110	130	110	110	130	130	130
d	[mm]	1.5	1.5	1.5	1.5	1.65	1.65	1.65	1.6	1.6	1.6	1.6	2
s	[mm]	7	7	7	7	7	7	7	7	7	7	7	7
S1	[mm]	10	10	10	10	10	10	10	10	10	10	10	10
X	[mm]	177	187	204	230	177	187	208	177	187	203	210	239
X1	[mm]	143	146	156	173	143	146	157	143	145	155	158	175
Stroke S	[mm]	3.6	3.6	4.8	6.4	3.6	3.6	4.8	3.6	3.6	4.8	4.8	6.4

18 Dimension sheet - VESTA sterile valves tank bottom valve H_A/T/H

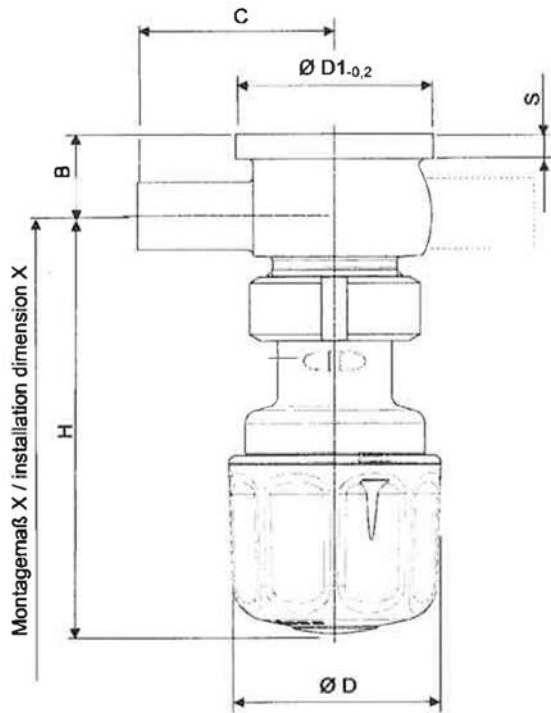

Fig.48: VESTA tank bottom valve H_A/T/H with housing for welding

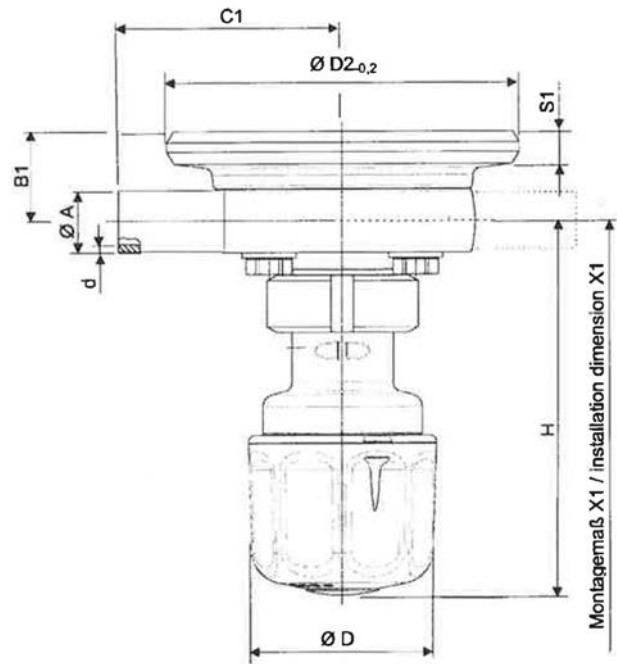

Fig.49: VESTA tank bottom valve H_A/T/F/H with housing for flanging

Dimension sheet - VESTA sterile valves tank bottom valve H_A/T/H

Dimension		DN10	DN15	DN20	DN25	0.5"OD	0.75"OD	1" OD	ISO 13.5	ISO 17.2	ISO 21.3	ISO 26.9	ISO 33.7
B	[mm]	26	23	29	35	26.3	23	28	25.8	24	30	27	33
B1	[mm]	31	28	34	37	31.3	28	33	31	29	35	32	35
C	[mm]	55	55	65	70	55	55	65	55	55	65	65	70
C1	[mm]	70	70	85	85	70	70	85	70	70	85	85	85
H	[mm]	114	118	118	125	114	118	118	114	116	118	122	126
Ø A	[mm]	13	19	23	29	12.7	19.05	25.4	13.5	17.2	21.3	26.9	33.7
Ø D	[mm]	59	59	59	59	59	59	59	59	59	59	59	59
Ø D1-0.2	[mm]	54.9	54.9	79.9	84.9	54.9	54.9	79.9	54.9	54.9	79.9	79.9	84.9
Ø D-0.2	[mm]	110	110	130	130	110	110	130	110	110	130	130	130
d	[mm]	1.5	1.5	1.5	1.5	1.65	1.65	1.65	1.6	1.6	1.6	1.6	2
s	[mm]	7	7	7	7	7	7	7	7	7	7	7	7
S1	[mm]	10	10	10	10	10	10	10	10	10	10	10	10
X	[mm]	160	171	178	194	160	171	181	160	170	179	186	202
X1	[mm]	126	130	130	173	126	130	130	126	128	130	134	138
Stroke S	[mm]	3.6	3.6	4.8	6.4	3.6	3.6	4.8	3.6	3.6	4.8	4.8	6.4

19 Dimension sheet - housing connection H_A/T/F

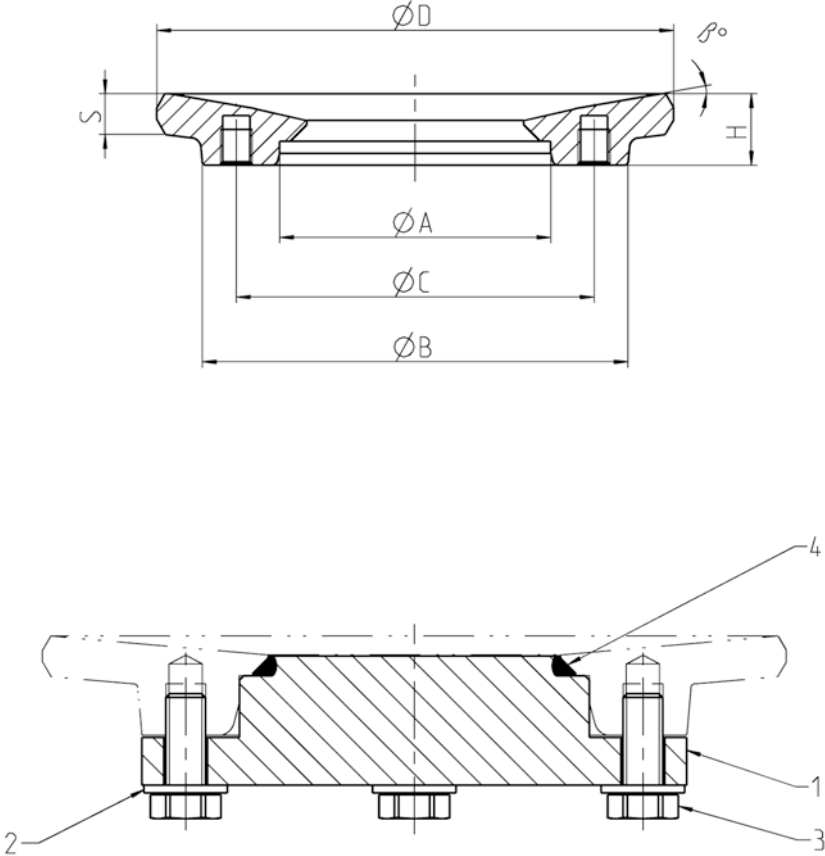

Fig.50

Dimension sheet - housing connection H_A/T/F

Designation	Material	Material no.				
		H_A		T_A		
		DN10/DN15 ISO13.5/ISO17.2 0.5"OD/0.75"OD	DN20/DN25/DN32 ISO21.3/ISO26.9/ ISO33.7 1"OD	DN40/DN50 ISO42.4/ISO48.3 1.5"OD/2"OD	DN65/DN80 ISO60.3/ISO76.1/ ISO88.9 2.5"OD/3"OD	DN100 ISO114.3 4"OD
Housing connection	1.4404	221-003304	221-002949	221-555.02	221-555.03	221-555.04
	1.4435	221-001631	221-001633	221-002943	221-002944	221-003702
Dimensions						
Ø A		48.2	68.2	88.2	127.2	158.2
Ø B		81	107	137	183	213
Ø C		65	90	115	157	188
Ø D		110-0.2	130-0.2	187-0.5	237-0.5	267-0.5
S		10	10	10	10	10
β°		14	13	5	5.3	5.1
H		18	18	25	30	30

Item	Designation	Material	DN10/DN15	DN20/DN25/DN32	DN40/DN50	DN65/DN80	DN100
1	Blind flange	1.4404	--	--	221-002406	221-002629	221-002630
2	Ring	A2	921-014	921-014	921-018	921-021	921-021
3	Hex head screw	A2	901-054	901-061/901-305	901-095	901-143	901-143
4	O-ring	EPDM	930-558	930-143	930-319	930-154	930-365
		FKM	930-565	930-596	930-666	930-667	930-619

Required welding fixture H_A and T_A complete						
Material no.		229-103.68	229-103.70	229-103.54	229-103.55	229-103.56

Attention!

When welding in the housing connection, welding instructions 221RLI009047DE and 221RLI006235D must be observed.

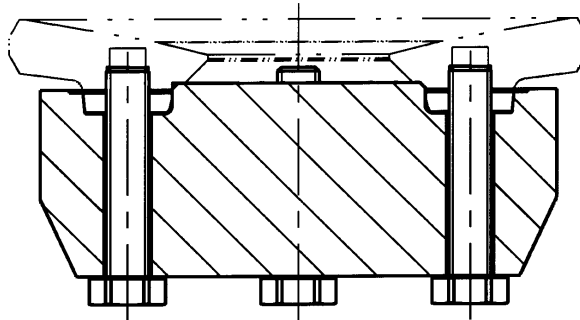

Fig.51

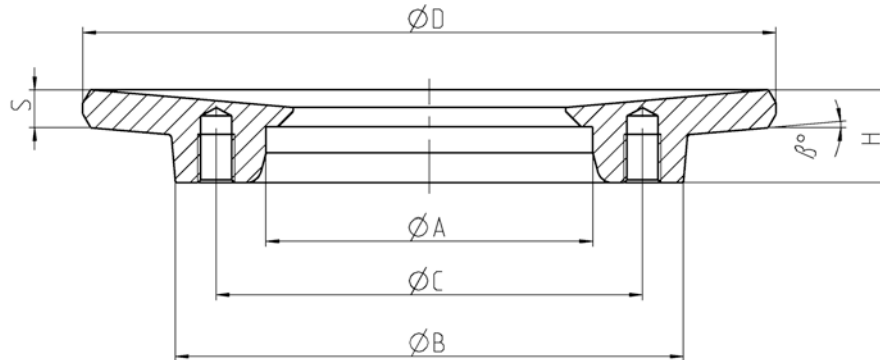

Fig.52

Designation	Material	Material no.							
		DN25 / 1"OD		DN50/DN40 / 1.5"OD/2"OD ISO42.4 / ISO48.3		DN80/DN65 / 2.5"OD/3"OD ISO 60.3 / ISO 76.1 / ISO 88.9		DN100 / 4"OD ISO 114.3	
Housing connection T_A	1.4404	221-555.01	221-555.05	221-555.02	221-555.06	221-555.03	221-555.07	221-555.04	221-555.08
	1.4435	--	--	221-002943	--	221-002944	--	221-003702	--
	1.4529	--	--	221-003299	--	--	--	--	--
	1.4539	--	--	221-003300	--	--	--	--	--
Dimensions(mm)									
S		10	12.7	10	12.7	10	12.7	10	12.7
$\varnothing A$		68.2		88.2		127.2		158.2	
$\varnothing B$		108		137		183		213	
$\varnothing C$		90		115		157		188	
$\varnothing D-0.5$		157		187		237		267	
β°		6		5		7		7	
H		25		25		30		30	

Item	Designation	Material	Material no.				
1	Blind flange	1.4404	--	--	221-002406	221-002629	221-002630
2	Ring	A2	--	--	921-018	921-021	921-021
3	Hex head screw	A2	--	--	901-095	901-143	901-143
4	O-ring	EPDM	--	--	930-319	930-154	930-365
		FKM	--	--	930-666	930-667	930-619

Required welding fixture T_A complete				
Order size	25	50/40	80/65	100
Material no.	229-103.53	229-103.54	229-103.55	229-103.56

Attention!

When welding in the flange, welding instructions 221RLI002575D for housing connection T_A must be observed.

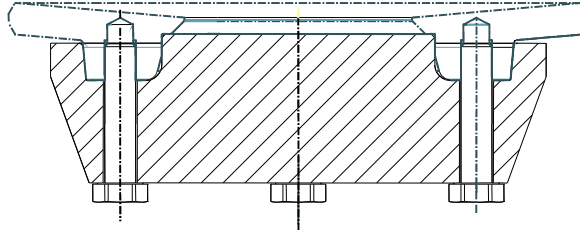

Fig.53

20 Welding instruction housing H_A/T for VESTA tank bottom valves DN10 to DN32; ISO13.5 to ISO33,7; 0.5"OD to 1"OD

Preparatory information	
Location	Büchen
Welding method of the manufacturer	141 WIG pulse
Welder	certified according to DIN EN 287-1 and AD-2000 leaflet HP3
Welding process	141 DIN EN ISO 4063
Type of preparation	Mechanical
Type of cleaning	Brushing or staining
Type of seam	DIN EN ISO 9692 K-seam, gap: b = 0mm
Workpiece thickness (mm)	t1 = 4, 5, 6, 7mm / t2 = 7mm
Specification of base materials	1.4435
Outside diameter	165, 200, 225
Heat input	Root 1, 2: < 9 kJ / cm
Heat input	Position 3,4: < 10 kJ / cm
Drawing of joint preparation	see Figure
Welding position	PA (flat position) PD (overhead)

Welding sequence
<p>Fig.54: Segment steps and drawing for joint preparation</p>

Information about the welding sequence						
Bead	Process	Filler material Ø (mm)	Amperage (A)	Voltage (V)	Type of current/ polarity electrode	Welding speed (cm/min)
Root	141	1.0	90 - 110	11 - 14	= -	3 - 7
Cover pass	141	1.2	105 - 125	11 - 14	= -	3 - 7

Information about the welding sequence	
Additional material	in agreement with the technical expert
Inert gas	DIN EN ISO 14175-I1
Root protection/forming gas	DIN EN ISO 14175-I1
Flow rates (l/min)	Inert gas: 13 - 15 Root protection: 10 - 20
Interpass temperature	T < 30°C

Seam preparation on the container				
t1	h	c	□	β
7	3	1	30°	30°
6	3	0	30°	30°
5	2.5	0	30°	30°
4	2	0	30°	30°

Welding sequence plan

You may only apply the pulse welding method.

Prerequisite: Welding may only be carried out only using a valve block that is connected to the forming gas (see 231ELI006854).

Carry out the following steps:

1. Staple with addition at eight opposite positions: first from the outside of the connection, then from the inside of the connection. Welding rod diameter: Ø1mm
2. Root position from the outside (root 1) in segments (see sketch). Start at position 1) and weld with filler metal (rod Ø1mm). Allow to cool down until workpiece and seam area temperature <30°C.
3. Weld root position from the inside (root 2) in segments (start is turned 45° compared to root 1) with filler metal (rod Ø1mm). Allow to cool until workpiece and seam area temperature <30°C.
4. Weld second layer from the inside (layer 3) with addition (rod Ø1.2mm). Rotate again the start of the weld of the segments by 45° at the beginning of root 2. Allow to cool down until workpiece and seam area temperature <30°C.
5. Weld second layer from outside (layer 4) (rod Ø1.2mm). Rotate weld start by 45° to layer 3.

Manufacturer / stamp	Location	Datum	Signature (welding supervisor)

21 Appendix

21.1 Lists

21.1.1 Abbreviations and terms

Abbreviation	Explanation
BS	British Standard
bar	Unit of measurement of pressure [bar] All pressure data expressed in [bar/psi] is assumed to be gauge pressure [bar _g /psi _g] unless explicitly specified otherwise.
approx.	approximately
°C	Unit of measurement of temperature [degree Celsius]
CIP	Cleaning in place
D-tec	Stem diaphragm technology
dm ³ n	Unit of measurement of volume [cubic decimetre] standard volume (standard litres)
DN	DIN nominal width
DIN	German standard issued by DIN (Deutsches Institut für Normung e.V., German Institute for Standardization)
EN	European Standard
EPDM	Material designation Brief designation according to DIN/ISO 1629: Ethylene-propylene-diene- rubber
°F	Unit of measurement of temperature [degree Fahrenheit]
FKM	Material designation, short designation according to DIN/ISO 1629: Fluorine rubber
h	Unit of measurement of time [hour]
IP	Protection class
ISO	International Standard of the International Organization for Standardization
kg	Unit of measurement of weight [kilogram]
kN	Unit of measurement of force [kilonewton]
Kv value	Flow coefficient [m ³ /s] 1 KV = 0.86 x Cv
l	Unit of measurement of volume [litre]
max.	maximum
mm	Unit of measurement of length [millimetre]
mm	Unit of measurement of length [micrometre]
M	Metric

Abbreviation	Explanation
NC	normally closed Air-to-close/spring-to-open action
Nm	Unit of measurement of work [newton metre] SPECIFICATION FOR THE TORQUE: 1 Nm = 0.737 lbft Pound-Force (lb) + Feet (ft)
NO	normally open Spring-to-close/air-to-open action
PA	Polyamide
PE-LD	Low-density polyethylene
psi	Anglo-American unit of measurement for pressure [pound-force per square inch] All pressure data expressed in [bar/psi] is assumed to be gauge pressure [barg/psig] unless explicitly specified otherwise.
PTFE	Polytetrafluoroethylene
SET-UP	Self-learning installation During commissioning and maintenance, the SET-UP procedure carries out all the necessary settings for the generation of messages.
SIP	Sterilization in place
AF	Indicates the size of spanners [width across flats]
TEFASEP gold	Sealing material for the valve seat seal
T.VIS	Tuchenhagen valve information system
V AC	Volt alternating current
V DC	Volt direct current
W	Unit of measurement of power [Watt]
TIG	Welding method Tungsten inert gas welding
Inch	Unit of measurement of length in the Anglo-American language area
Inch OD	Tube measurement according to British Standard (BS), outside diameter



We live our values.

Excellence · Passion · Integrity · Responsibility · GEA-versity

GEA Group is a global engineering company with multi-billion euro sales and operations in more than 50 countries. Founded in 1881, the company is one of the largest providers of innovative equipment and process technology. GEA Group is listed in the STOXX® Europe 600 Index.

GEA Germany

GEA Tuchenhausen GmbH
Am Industriepark 2-10
21514 Büchen, Germany

Tel +49 (0)4155 49 0
Fax +49 (0)4155 49 2035

gea.com/contact