



Preparation and Installation of the APX Rupture Disc Assembly

Continental Disc®
Corporation

WARNING

USER SHOULD READ AND THOROUGHLY UNDERSTAND THESE INSTRUCTIONS BEFORE INSTALLING RUPTURE DISC. THESE INSTRUCTIONS DO NOT PURPORT TO ADDRESS ALL OF THE SAFETY FACTORS ASSOCIATED WITH THE RUPTURE DISC'S USE IN SERVICE. IT IS THE RESPONSIBILITY OF THE USER TO ESTABLISH APPROPRIATE SAFETY, HEALTH, AND TRAINING MEASURES FOR THEIR PERSONNEL INSTALLING, SERVICING, OR WORKING IN AN AREA WHERE RUPTURE DISC ASSEMBLIES ARE IN USE. SERVICE AND/OR MAINTENANCE ON OR AROUND THE RUPTURE DISC DEVICE MUST NOT BE PERFORMED WHILE THE DEVICE IS SUBJECTED TO OPERATING PRESSURES AND/OR TEMPERATURES.

IT IS THE USER'S SOLE RESPONSIBILITY FOR DESIGN AND PLACEMENT OF RUPTURE DISCS WITHIN THEIR FACILITY AND UPON THE EQUIPMENT UPON WHICH THE RUPTURE DISC OF USER'S SELECTION IS TO BE LOCATED. IT IS USER'S SOLE RESPONSIBILITY FOR THE DESIGN OF ADEQUATE VENTING AND INSTALLATION OF ADEQUATE VENT PIPING OR DIRECTIONAL FLOW AFTER RUPTURE OCCURS WITH THE RUPTURE DISC AS INTENDED. WHEN SIZE IS SPECIFIED, CONTINENTAL DISC CORPORATION ASSUMES THAT ADEQUATE PROVISIONS HAVE BEEN MADE BY PURCHASER FOR PROPER VENTING OF A SYSTEM TO RELIEVE THE SPECIFIC PRESSURE. LOCATE RUPTURE DISC WHERE PEOPLE OR PROPERTY WILL NOT BE EXPOSED TO THE SYSTEM DISCHARGE IN CASE OF RUPTURE. VENT TOXIC OR FLAMMABLE FUMES OR LIQUIDS TO A SAFE LOCATION TO PREVENT PERSONAL INJURY OR PROPERTY DAMAGE.

IT IS THE USER'S SOLE RESPONSIBILITY TO SPECIFY THE BURST PRESSURE RATING OF A RUPTURE DISC AT A COINCIDENT TEMPERATURE AT WHICH THE RUPTURE DISC IS TO BE USED. A RUPTURE DISC IS A TEMPERATURE SENSITIVE DEVICE. THE BURST PRESSURE OF THE RUPTURE DISC IS DIRECTLY AFFECTED BY ITS EXPOSURE TO THE COINCIDENT TEMPERATURE. GENERALLY, AS THE TEMPERATURE AT THE RUPTURE DISC INCREASES, THE BURST PRESSURE DECREASES; INVERSELY, AS THE TEMPERATURE AT THE RUPTURE DISC DECREASES, THE BURST PRESSURE MAY INCREASE. FAILURE TO PROPERLY UTILIZE A RUPTURE DISC AT THE SPECIFIED COINCIDENT TEMPERATURE COULD CAUSE PREMATURE FAILURE OR OVERPRESSURIZATION OF A SYSTEM.

THE INSTANTANEOUS RELEASE OF PRESSURE FROM THE RUPTURE DISC CAN CREATE VIOLENT NOISES DUE TO THE DISCHARGE AT SONIC VELOCITY. IT IS THE USER'S SOLE RESPONSIBILITY TO PROTECT AGAINST HEARING DAMAGE TO ANY BYSTANDERS.

RUPTURE DISCS AND TAGS ARE MADE OF METAL FOILS OF VARYING THICKNESS. THE METAL EDGES MAY BE SHARP. PERSONNEL INSTALLING OR EXAMINING THE RUPTURE DISCS SHOULD PROTECT AGAINST CUTS OR INJURY WHEN HANDLING THE RUPTURE DISC. DO NOT LIFT A RUPTURE DISC BY ITS ATTACHED TAG.

PARTICLES MAY BE DISCHARGED WHEN THE RUPTURE DISC RUPTURES. THESE PARTICLES MAY BE PART OF THE RUPTURE DISC ITSELF, OR OTHER ENVIRONMENTAL MATTER IN THE SYSTEM. IT IS THE USER'S SOLE RESPONSIBILITY TO ASSURE THAT THESE PARTICLES ARE DIRECTED TO A SAFE AREA TO PREVENT PERSONAL INJURY OR PROPERTY DAMAGE.

THERE IS NO GUARANTEE OF RUPTURE DISC LIFE. SUCH LIFE SPAN IS AFFECTED BY CORROSION, CREEP AND FATIGUE, AND PHYSICAL DAMAGE. THESE CONDITIONS WILL DERATE THE RUPTURE DISC TO A LOWER SET PRESSURE. THE CUSTOMER AND/OR USER SHOULD BE PREPARED TO HANDLE PREMATURE FAILURE OF THE RUPTURE DISC. THE MEDIA OR OTHER ENVIRONMENTAL CONDITIONS SHOULD NOT ALLOW ANY BUILDUP OR SOLIDIFICATION OF MEDIA TO OCCUR ON A RUPTURE DISC. THIS MAY INCREASE THE PRESSURE SETTING OF THE RUPTURE DISC.

CUSTOMER AND/OR ITS INSTALLER SHALL BE SOLELY RESPONSIBLE FOR THE PROPER INSTALLATION OF SELLER'S HOLDERS AND RUPTURE DISCS INTO A SYSTEM. CUSTOMER AND/OR ITS INSTALLER SHALL BE SOLELY RESPONSIBLE FOR IMPROPER INSTALLATION AND PHYSICAL DAMAGE RESULTING THEREFROM, INCLUDING BUT NOT LIMITED TO, DAMAGE RESULTING FROM LEAKAGE, IMPROPER TORQUING OR SEATING OF A RUPTURE DISC OR FAILURE TO FOLLOW INSTALLATION INSTRUCTIONS WHERE PROVIDED.

RUPTURE DISCS ARE PRECISION SAFETY DEVICES AND MUST BE INSTALLED PROPERLY. RUPTURE DISCS MUST BE INSTALLED BY TRAINED, KNOWLEDGEABLE INSTALLERS AND ONLY WITHIN ENVIRONMENTS SUITABLE AND APPROPRIATE FOR A RUPTURE DISC. CARE MUST BE USED IN A FACILITY'S DESIGN TO PROTECT BOTH THE RUPTURE DISC FROM INADVERTENT DAMAGE WHICH COULD CAUSE ITS PREMATURE RELEASE AND TO PROTECT INDIVIDUALS EXPOSED TO HAZARDS CREATED BY SUCH SUDDEN RELEASE.

PROPER INSTALLATION OF A RUPTURE DISC IS CRITICAL TO PERFORMANCE AND TO SAFETY. FAILURE TO PROVIDE PROPER SEATING OF A RUPTURE DISC MAY AFFECT RUPTURE DISC PERFORMANCE, BURST PRESSURE ACCURACY AND MAY RESULT IN ITS PREMATURE FAILURE.

I. Safety Precautions Before Installation

1. The APX rupture disc is a precision instrument and must be handled with extreme care. Rupture discs should be installed only by qualified personnel familiar with rupture discs and proper piping practices.
2. The APX rupture disc is to be installed in the APX holder.
3. The indentation at the base or the apex of the rupture disc is a factory installed, precision indentation (refer to **Figure A**). Do not install rupture disc if there is any damage in the dome area beyond the factory installed indentations. A damaged rupture disc is any rupture disc with visible nicks or dents in the dome.
4. Continental Disc Corporation does not recommend reinstalling a rupture disc that has been removed from the holder as reinstallation may adversely affect the joint sealing capabilities and/or performance of the rupture disc.
5. See rupture disc tag to verify set pressure, operating temperature, and all other operating parameters.

Figure 'A'

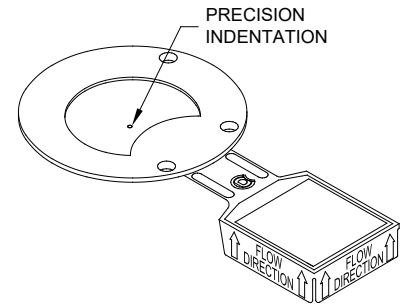

II. Preparation of Holders for Installation

New Installation

Clean all foreign material from the rupture disc sealing area of both the holder inlet and outlet.

Replacement Installation

1. If the Burst Disc Indicator (B.D.I.®) Alarm System is used, disconnect the alarm strip from the monitor by unplugging the B.D.I. connector from the lead wire connector.
2. Remove the holder from the system and place on a flat surface.
3. Disassemble the holder by loosening the pre-assembly screws. Lift the holder outlet up and set aside; then remove the burst rupture disc.
4. Clean the rupture disc sealing area of both the holder inlet and outlet. These surfaces must be completely clean and free of all rust, corrosion, and foreign material to ensure a proper seal. Use of solvents, steel wool, or fine emery cloth is permissible. Do not re-machine. Do not use scraper or abrasives.
5. Inspect the rupture disc sealing area for nicks, scratches, or pitting. If any of these conditions are present, consult the factory for repair.
6. Remove any adhered gasket material from previous installation.

III. Assembly of the Rupture Disc and Holder (See Figure B)

Component parts of the APX rupture disc assembly are illustrated in the proper installation sequence.

1. If the B.D.I. Alarm System is to be used, refer to the Universal B.D.I. Assembly installation instructions for additional details.
2. Carefully remove and discard any shipping protectors furnished with rupture discs or holder. **DO NOT INSTALL A SHIPPING PROTECTOR IN A HOLDER ASSEMBLY.**
3. Place the holder inlet on a flat surface with the alignment pins pointing up.
4. Place the rupture disc over the alignment pins with the dome side down.
5. Position the holder outlet carefully onto the alignment pins as shown, ensuring that the rupture disc is not damaged.
6. Fasten the assembly together by tightening the pre-assembly screws.

Figure 'B'

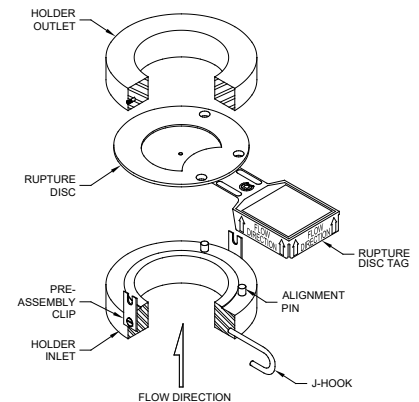

IV. Installation of the APX Assembly Into the System (See Figure C)

1. Before placing the assembly into the system, ensure that the companion flange gasket surfaces are clean and free of all rust, corrosion, and foreign material.
2. A J-Hook is provided in the holder inlet to ensure correct installation of the assembly relative to flow direction. Prior to installation of the assembly, the corresponding inlet companion flange must be drilled to accommodate the J-Hook. Refer to the J-Hook Installation Guide for locating and drilling specifications.
3. Install the APX assembly and customer furnished gaskets **WITH ALL FLOW ARROWS POINTING IN THE PROPER FLOW DIRECTION** and the J-Hook inserted into the drilled companion flange.
4. If a outlet protective cover is ordered, install it between the APX rupture disc assembly and the gasket of the outlet companion flange.
5. Install lightly oiled free running studs and nuts to finger tightness. Using a cross torquing pattern (see Figure D), torque each nut with a calibrated torque wrench at 20% increments of recommended torque value (see Table 1, Page 4). Repeat 20% increments and cross-torquing pattern until final torque value is achieved. Recheck all nuts in rotational sequence at final torque value. These values are based on using gasket materials having a gasket factor of 2.75, gasket-seating stress of 3,700 psi, and stud and nut material per ASME SA193-B7 and SA194-2H respectively, with a stress of up to 30,000 psi. The use of studs and nuts with lower strength may prove unsatisfactory.

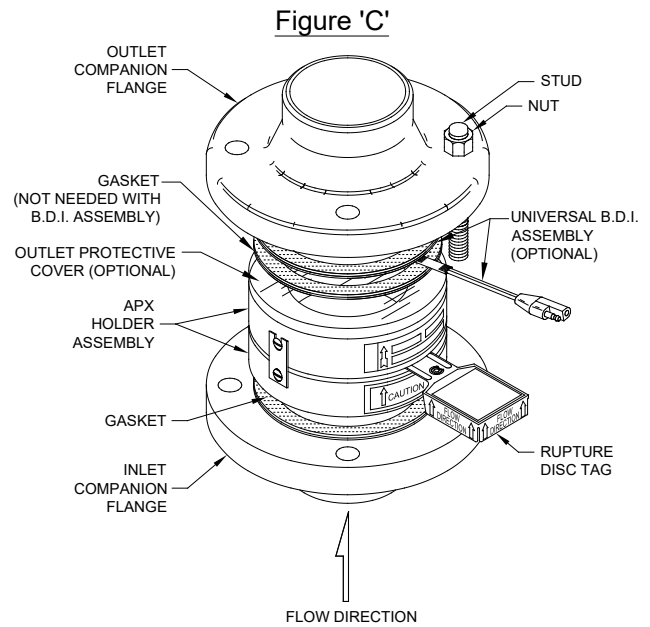
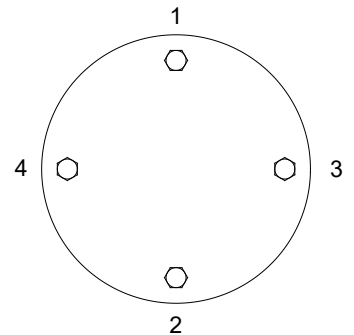

Figure 'D'
EXAMPLE OF
BOLT TORQUE SEQUENCE



V. Preventative Maintenance

1. Risk assessment and an annual rupture disc replacement are recommended. Rupture disc service life is determined by system operating conditions. The effects of severe pressure/vacuum cycles, corrosion, temperature variations, or other adverse conditions must be evaluated by the user through actual service experience to determine optimal service life.
2. **IF THE RUPTURE DISC IS NOT REPLACED PERIODICALLY WHEN EXPOSED TO THESE CONDITIONS, PREMATURE FAILURE OF THE RUPTURE DISC MAY OCCUR, THEREBY DISCHARGING THE PROCESS MEDIA.**
3. To avoid extended downtime, maintain three spare rupture discs in stock at all times for each holder in use. The number of spares required ultimately will be determined by service conditions.

VI. Customer Service

If you wish to discuss your application, installation, or maintenance, please contact the Customer Service Department at one of the addresses shown on the last page of these instructions.

Recommended Torque Values for APX
Rupture Discs Sizes 1" through 8"

TABLE 1

SIZE		COMPANION FLANGE RATING			RECOMMENDED TORQUE VALUE		SIZE		COMPANION FLANGE RATING			RECOMMENDED TORQUE VALUE	
IN	MM	ANSI	DIN	JIS	FT•LB	N•m	IN	MM	ANSI	DIN	JIS	FT•LB	N•m
1	25	150	---	---	35	47	3	80	150	---	---	65	88
1	25	---	10/16	---	33	45	3	80	---	10/16	10	33	45
1	25	---	---	10/16/20	44	60	3	80	---	---	16/20	41	56
1	25	300/600	---	---	45	61	3	80	300/600	---	---	120	163
1	25	---	25/40	---	34	46	3	80	---	25/40	---	101	137
1	25	---	63/100	30/40	45	61	3	80	---	63	30/40	126	171
1	25	900/1500	---	---	65	88	3	80	900	---	---	180	244
1	25	---	160	---	47	64	3	80	---	100	---	151	205
1	25	---	250	---	58	79	3	80	---	160	---	194	263
1-1/2	40	150	---	---	35	47	4	100	150	---	---	65	88
1-1/2	40	---	10/16	10/20	44	60	4	100	---	10/16	10	66	89
1-1/2	40	300/600	---	---	120	163	4	100	---	---	16/20	82	111
1-1/2	40	---	25/40	---	101	137	4	100	300	---	---	120	163
1-1/2	40	---	63/100	30/40	126	171	4	100	---	25/40	---	126	171
1-1/2	40	900/1500	---	---	260	352	4	100	---	---	30	139	188
1-1/2	40	---	160	---	205	278	4	100	600	---	---	180	244
1-1/2	40	---	250	---	246	334	4	100	---	---	40	178	241
2	50	150	---	---	65	88	6	150	150	---	---	120	163
2	50	---	10/16	10	66	89	6	150	---	10/16	10	126	171
2	50	---	---	16/20	33	45	6	150	---	---	16/20	92	125
2	50	300/600	---	---	65	88	6	150	300	---	---	120	163
2	50	---	25/40	---	131	178	6	150	---	25/40	---	227	308
2	50	---	---	30/40	66	89	6	150	---	---	30	151	205
2	50	900/1500	---	---	180	244	6	150	600	---	---	275	373
2	50	---	63	---	164	222	6	150	---	---	40	260	352
2	50	---	100	---	197	267							
2	50	---	160	---	389	527	8	200	150	---	---	130	176
2	50	---	250	---	194	263	8	200	---	10	---	136	184
							8	200	---	16	10	91	123
							8	200	---	---	16/20	100	136
							8	200	300	---	---	180	244
							8	200	---	25	30	194	263
							8	200	---	40	---	219	297



Continental Disc[®]
Corporation

HEADQUARTERS //
3160 W. Heartland Drive
Liberty, MO 64068 USA
Ph (816) 792-1500
Fax (816) 792-2277
sales@contdisc.com
contdisc.com